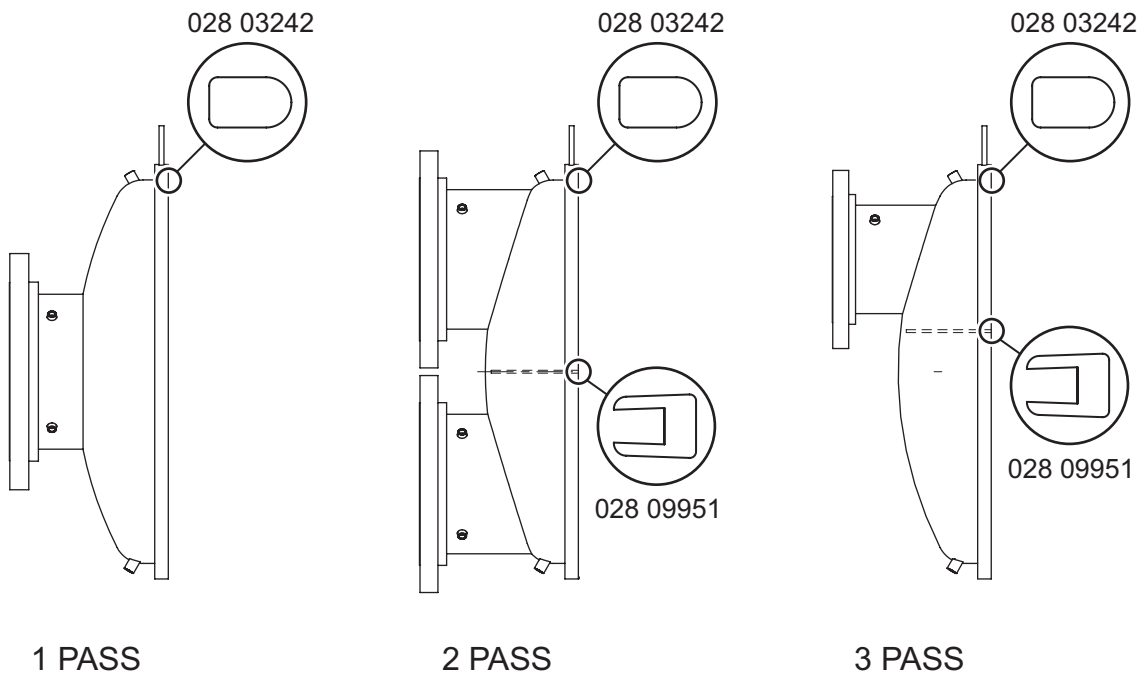

**TABLE 68 - CONDENSER 300# COMPACT WATERBOX (MOD C)**

SHELL	1 PASS		2 PASS		3 PASS	
	GASKET P/N	FEET REQ'D	GASKET P/N	FEET REQ'D	GASKET P/N	FEET REQ'D
L, M	028 03242	26'	028 09951	4'	028 09951	8'
			028 03242	26'	028 03242	26'
B	-	-	-	-	-	-
C	028 03242	30'	028 09951	6'	028 09951	10'
			028 03242	30'	028 03242	30'
D, E	028 03242	33'	028 09951	5'	028 09951	10'
			028 03242	33'	028 03242	33'
F	028 03242	35'	028 09951	6'	028 09951	11'
			028 03242	35'	028 03242	35'
K	028 03242	38'	028 09951	6'	028 09951	12'
			028 03242	38'	028 03242	38'

**NOTE:**

When ordering Gasket Material specify length required by replacing the -000 with either -025 for 25', -050 for 50', or -100 for 100'.



**FIGURE 81 - CONDENSER 300# COMPACT WATERBOX (MOD C)**

LD15188