

TABLE 54 - EVAPORATOR 300# MARINE WATERBOX (MOD A)

SHELL	1 PASS		2 PASS		3 PASS	
	GASKET P/N	FEET REQ'D	GASKET P/N	FEET REQ'D	GASKET P/N	FEET REQ'D
XF	028 03242	76'	028 09951	23.5'	028 09951	23.5'
XH			028 03242	57'	028 03242	76'
YF	028 03242	76'	028 09951	23.5'	028 09951	23.5'
YG			028 03242	57'	028 03242	76'
YH						
ZF	028 03242	76'	028 09951	23.5'	028 09951	28.5'
ZG			028 03242	57'	028 03242	92'
ZH						
AF	028 03242	76'	028 09951	23.5'	028 09951	28.5'
AG			028 03242	57'	028 03242	92'
AH						

NOTE:

When ordering Gasket Material specify length required by replacing the -000 with either -025 for 25', -050 for 50', or -100 for 100'.

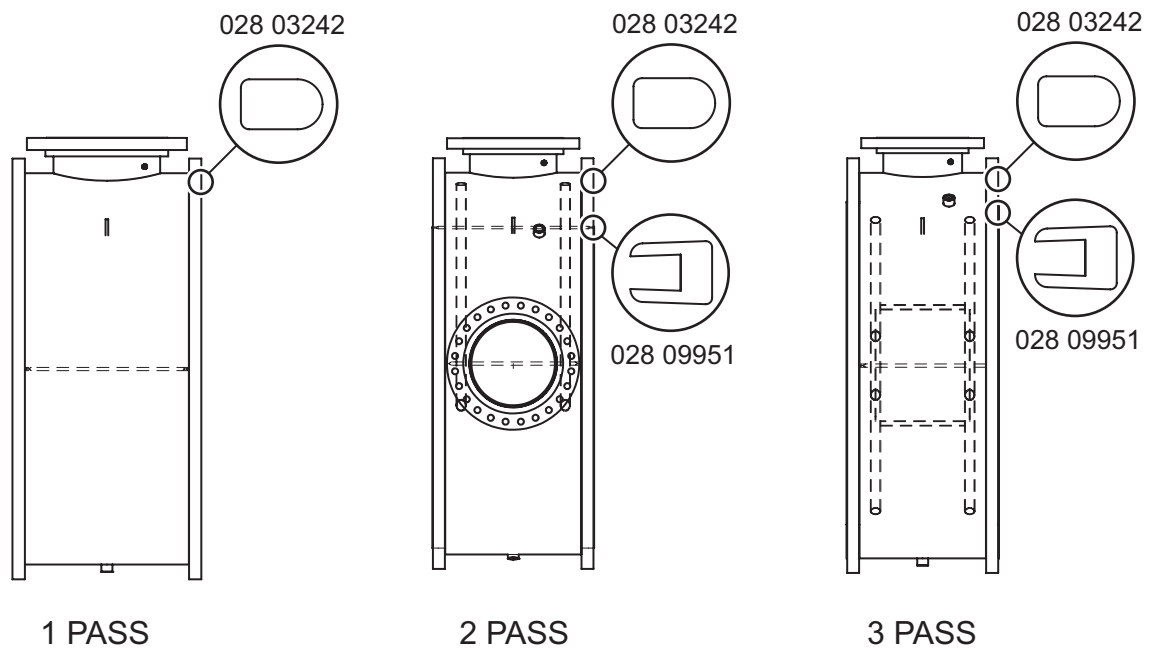

FIGURE 67 - EVAPORATOR 300# MARINE WATERBOX (MOD A)