

CONDENSER COMPACT WATERBOX

TABLE 51 - CONDENSER 150# COMPACT WATERBOX (MOD A)

SHELL	1 PASS		2 PASS		3 PASS	
	GASKET P/N	FEET REQ'D	GASKET P/N	FEET REQ'D	GASKET P/N	FEET REQ'D
XA	028 03242	28'	028 09951 028 03242	4.5' 28'	028 09951 028 03242	8.5' 28'
XB						
XC						
XD						
YA	028 03242	28'	028 09951 028 03242	5' 33'	028 09951 028 03242	10' 33'
YB						
YC						
YD						
ZA	028 03242	28'	028 09951 028 03242	5.5' 35'	028 09951 028 03242	11' 35'
ZB						
ZC						
ZD						
AA	028 03242	28'	028 09951 028 03242	5.5' 35'	028 09951 028 03242	11' 35'
AB						
AC						
AD						

NOTE:

When ordering Gasket Material specify length required by replacing the -000 with either -025 for 25', -050 for 50', or -100 for 100'.

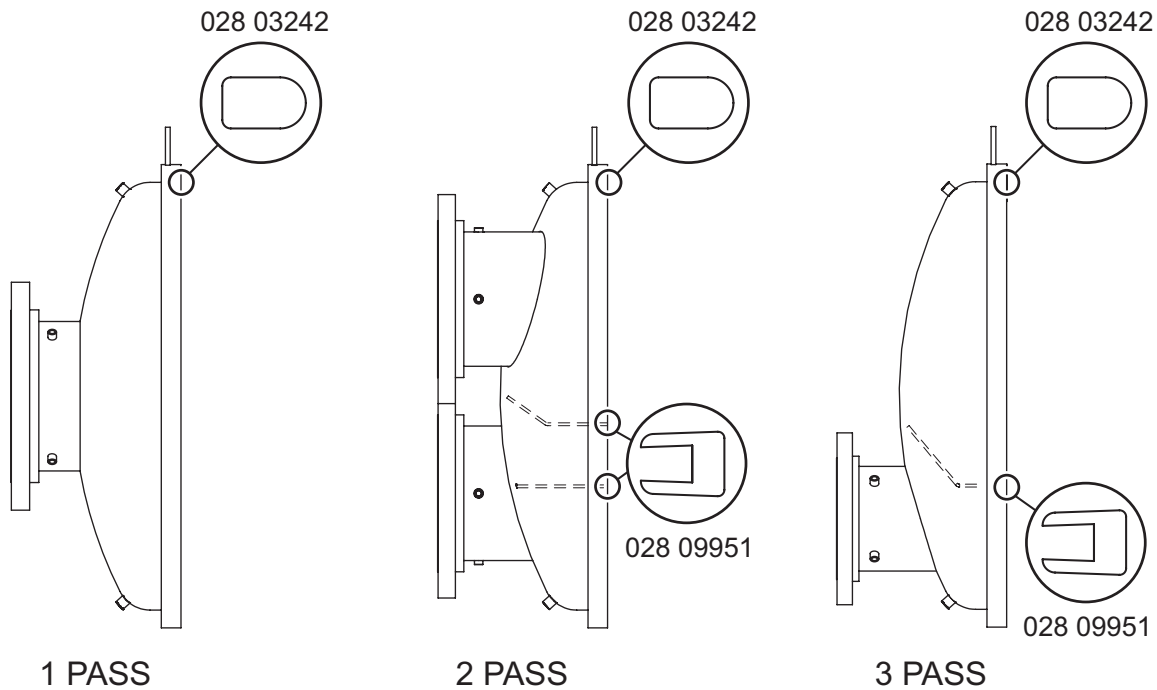

LD15192

FIGURE 64 - CONDENSER 150# COMPACT WATERBOX (MOD A)