

TOOLS

Tool Description	Part No.
1. John Crane Seal Puller	364-37059
2. Bearing Puller – Required to Remove and reinstall bearing in bearing head	364-37051
3. Unloading Sleeve Clip – Required to disassemble unloading sleeve from cylinder liner (2 Req'd.) (Refer to accompanying photo)	064-37002
4. Valve Clip (2 Req'd)	064-37274

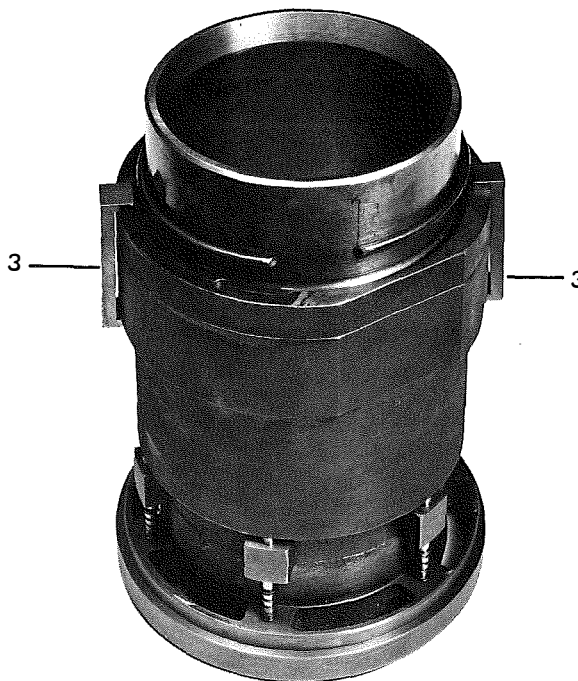

OIL COOLING COMPONENTS

Part Description	Part No.
Water Cooled Oil Cooler For Ammonia Units	366-43124
Liquid Strainer For Liquid Injection Oil Cooler	364-35651
Valve, Solenoid For Liquid Injection Oil Cooler	025-17496
Control, Temp. For Liquid Injection Oil Cooler	025-17499
Oil Cooler For External Ref. Cooled Oil Cooler	366-43124
Thermal Expansion Valve Ref. Cooled Oil Cooler	025-19982
Liquid Strainer Ref. Cooled Oil Cooler	364-44855
Solenoid Valve Ref. Cooled Oil Cooler	025-17496

REPLACEMENT GASKET KITS

Model Compr.	Kit Part No.
RS44, RW44	364-37762
RS64, RW64	364-37763
RS84, RW84	364-37764
RS124, RW124	364-37765
RS164, RW164	364-37766

REPLACEMENT COMPRESSORS

Model	Standard Replacement		Replacement For Y-53 & G Models	
	Ammonia	Halocarbon	Ammonia	Halocarbon
4 Cylinder	364-42701004	364-42701005	REFER TO FORM 180.55-NM1	
6 Cylinder	364-42702004	364-42702005		
8 Cylinder	364-42703004	364-42703005		
12 Cylinder	364-42704004	364-42704005		
16 Cylinder	364-42705004	364-42705005		

MISCELLANEOUS

Control Transformer Primary Voltage:	Part No.
240/480	025-12012
550/600	025-12591
Discharge Thermometer	026-21976
Oil Temp. Thermometer	026-21975

York International Corporation

Applied Systems

Post Office Box 1592-36BE

York Pennsylvania 17405-1592

Telephone 717 771 7890

YORK