

Item	Description	Part No.
1	Spacer, Seal Ass'y. Complete	364-31552
2	Spacer, Seal Bare	064-28859
3	Cap, Seal, Oil Relief Valve	065-16729
4	Gasket	065-21657
5	Spring, Helical	029-06143
6	Plunger, Oil Relief Valve	065-01331
7	Pin, Insert 1/4 Dia. x 3/4 Lg. (2 Req'd.)	029-04750
8	Plug, Pipe 1/4	023-01972
9	Connr., FLA 1/2 Tube x 3/8 NPTE	023-09675

FIG. 17— SEAL SPACER ASSEMBLY

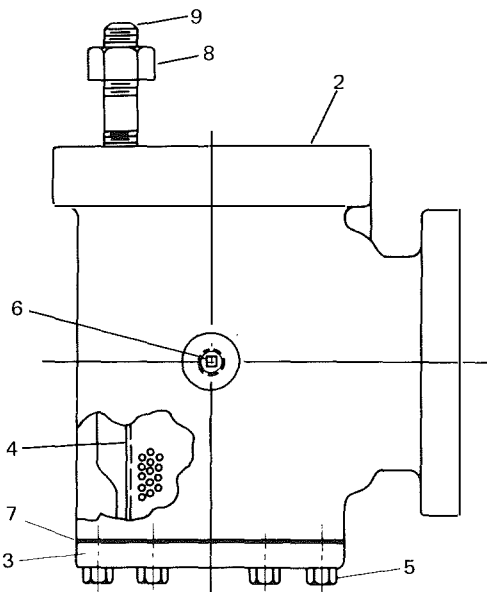

Item	Description	Part No.	
		RW44,64	RW84
1	Elbow, Strainer, Suction (Complete Assembly) (Includes Items 2, 3, 4, 5 & 6)	364-31544	364-31545
2	Elbow, Suction	064-28863	064-28864
3	Cover, Strainer	064-28860	064-28860
4	Strainer, Suction	029-13435	029-13435
5	Screw, Cap. (Strainer Cover) (6 Req'd.)	021-01483	021-01483
6	Plug, Pipe	023-01972	023-01972
7	Gasket, Suction Elbow	064-30111	064-28963
8	Nut, Hex (8 per Elbow)	021-00504	021-00513
9	Stud (8 per Elbow)	070-00393	070-00152

FIG. 18— SUCTION ELBOW (4, 6 & 8 Cylinder Models)