

ITEM NO.	DESCRIPTION	PART NO.
24	Piston Assembly Z4H, Z4K, Z6N, Z6S Z4J, Z4M, Z6R Z6W, Z6AE Z6AE	665-25315 665-25316 665-25316 365-25353-000
24A	Piston Z4H, Z4K, Z6N, Z6S Z4J, Z4M, Z6R Z6W, Z6AE Z6AE	065-25226 065-25239 065-25239 065-25322
24B	Compression Ring Z4H, Z4K, Z6N, Z6S Z4J, Z4M, Z6R Z6W, Z6AE Z6AE	029-20220 029-20226 029-20226 029-20901
24C	Expander Ring Z4H, Z4K, Z6N, Z6S Z4J, Z4M, Z6R Z6W, Z6AE Z6AE	028-20221 028-20227 028-20227 Not Used
24D	Wiper Ring Z4H, Z4K, Z6N, Z6S Z4J, Z4M, Z6R Z6W, Z6AE Z6AE	029-20222 029-20228 029-20228 028-20902
24E	Piston Pin	029-20218
24F	Retaining Ring (2 Req'd. Per Piston)	029-20219

#24811A

FIG. 5 — PISTON ASSEMBLY

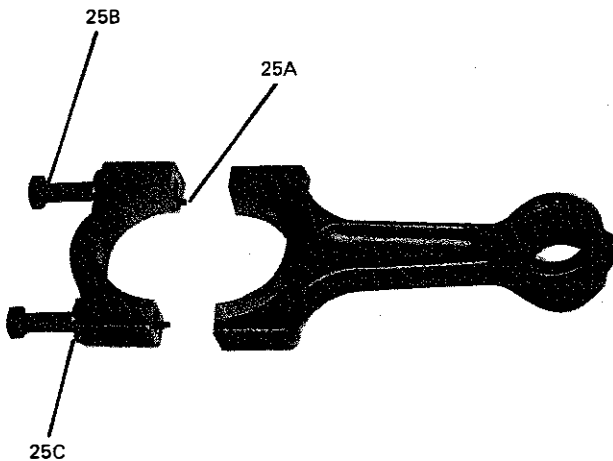

ITEM NO.	DESCRIPTION	PART NO.
25	Connecting Rod Assembly Z4H, Z4J, Z6N, Z6R Z4K, Z4M, Z6S, Z6W, Z6AE	365-25229 365-25242
25A	Dowel Pin (2 Req'd. / Rod)	029-19802
25B	Screw (2 Req'd. / Rod)	021-09643
25C	Washer (2 Req'd. / Rod — 10 / Pkg.)	221-01262-800

#24811B

FIG. 6 — CONNECTING ROD ASSEMBLY