

6. Using the bearing removal tool as shown in Fig. 41, Detail A, remove the old bearings from the housing. Bearings are removed one at a time in a similar manner from opposite ends of the bearing head.
7. Apply clean oil to the outside surface of the new bearings and to the inside portions of the bearing head into which the bearings are to be pressed.
8. Using the bearing removal tool as shown in Fig. 41, Detail B, pull the bearings into the bearing head one at a time from opposite ends, taking care that the bearings enter the bearing head squarely. The "seam" in bearing -C- should be at the top; the "seam" in bearings -A- and -B- should be turned 90° to either side. Continue to pull the bearings into the head until they are positioned as shown in Fig. 41, Detail C.
9. Inspect both ends of the bearings for and, if present, remove any burrs or metal shavings that result from the insertion.
10. Reinstall the bearing head. Be sure the bearing head is properly aligned with the oil passages (oil pressure regulating valve is at 6 o'clock position).

Crankshaft

The compressor crankshaft can be removed from either end of the compressor depending on which end is

more accessible. To remove the crankshaft, proceed as follows:

1. Drain the oil from the compressor. Remove the crankcase hand hole cover plates, discharge manifold, cylinder head, access covers, suction and discharge valve assemblies, pistons and connecting rods, motor cover, and rotor following procedures outlined previously.
2. Using suitable timber, support the crankshaft inside the crankcase.
3. Determine from which end the crankshaft is to be removed and remove the bearing head from that end of the compressor following procedures outlined previously.
4. Using two people, carefully remove the crankshaft from the compressor.
5. If the crankshaft is removed through the pump end, the thrust collar will probably remain in place in the compressor on the motor end. Be sure that this thrust collar is properly positioned on the roll pin before reinstalling the crankshaft. Check thrust clearance, after reassembly for allowable range of .013 - .038".
6. Reassemble the compressor by following the above procedure in reverse order.

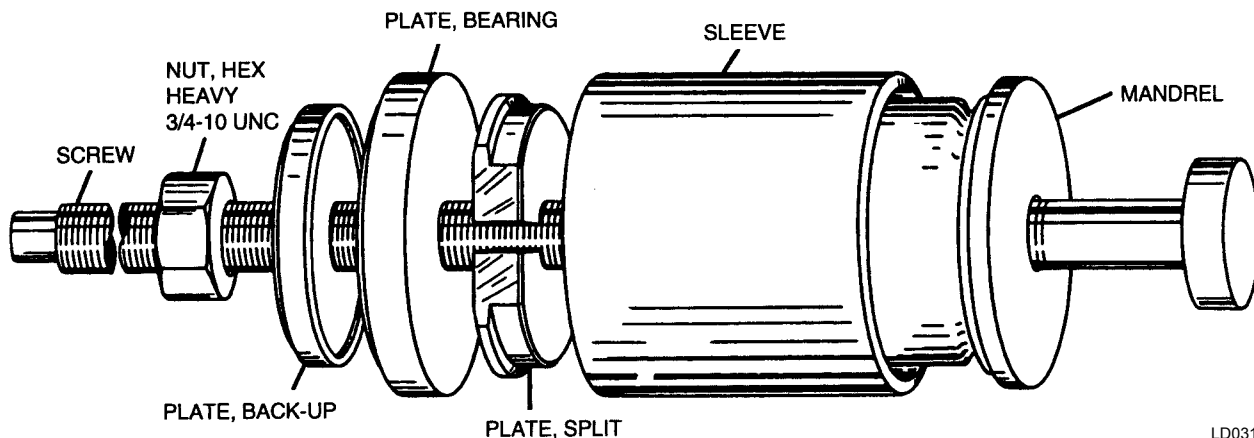

FIG. 42 – BEARING REMOVAL TOOL (PART NO. 364-37260-000)