

OIL CHARGING / PRIMING PUMP

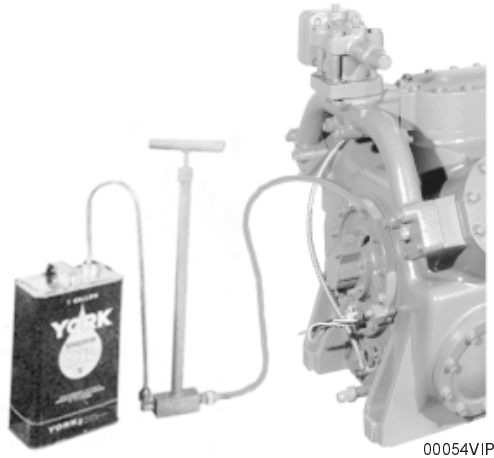

OIL CHARGING PUMP / OIL PRIMER

YORK's specially designed SUPER Oil Charging Pump is a real convenience to anyone operating, maintaining or servicing Refrigerant Compressors. It provides an easy means of charging oil into the compressor via the Schader valve access port on the oil pump without pumping a vacuum on the crankcase.

It eliminates the difficulties often encountered by inexperienced operators not familiar with pump-down procedures. It prevents air from getting into the crankcase air which eventually would have found its way to the condenser, resulting in excessive condensing pressures and inefficient operation.

SERVICE AIDS

Crankshaft pre-lube service at start-up and after long idle periods is recommended.

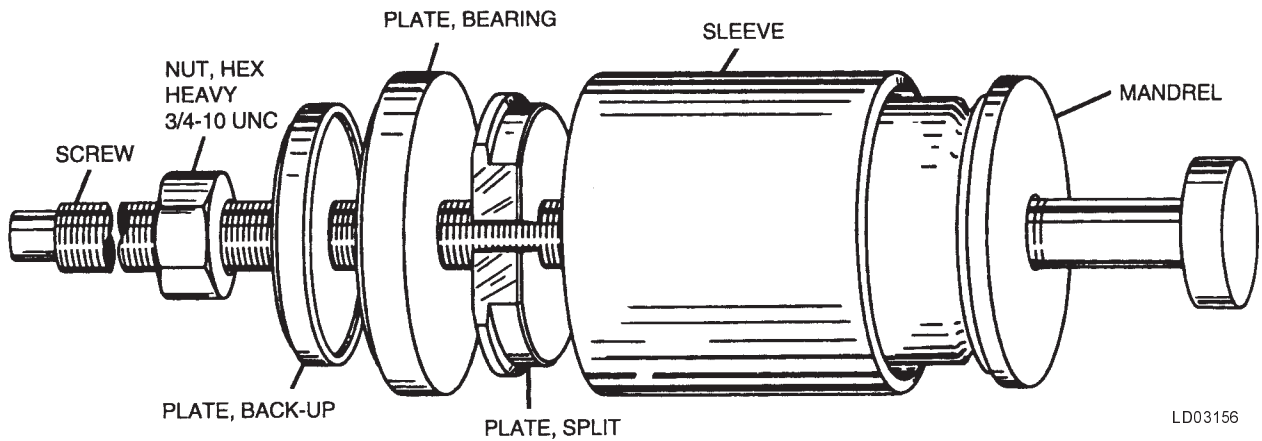

FIG. 22 – BEARING REMOVAL TOOL PART NO. 364-37260-000