

ITEM NO.	DESCRIPTION	PART NO.
Ⓢ 28	Plate, Suction Valve Ass'y. Includes:	664-42718
28A	Plate, Valve	064-42716
28B	Valve, Suction	064-43011
28C	Spring (24/Pk'g.—6 Springs Req'd Per Valve Ass'y.)	229-13813-800

FIG. 5 — SUCTION VALVE PLATE ASSEMBLY (ALSO SEE TABLES 4 & 5, PAGE 12)

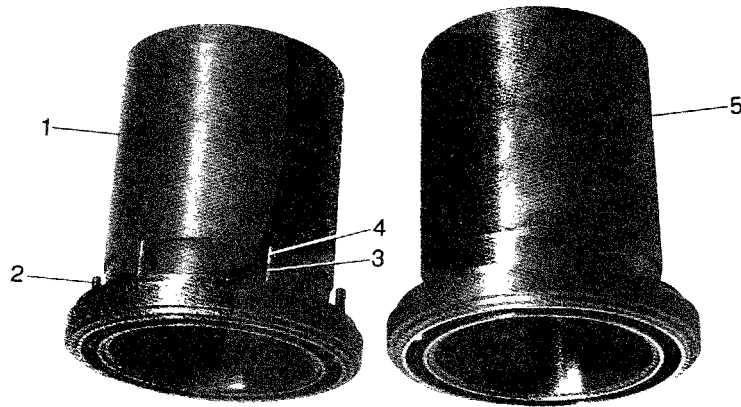



ITEM NO.	DESCRIPTION	PART NO.		
		4 Cyl.	6 Cyl.	8 Cyl.
CYLINDER SLEEVE — UNLOADING		 SEE FIGURE 10 FOR LOCATIONS		
Ⓢ 29 I	Sleeve, Cylinder Ass'y. (No. Req'd. See Fig. 10)	664-47224	664-47224	664-47224
29A	Sleeve, Cylinder	664-21667	664-21667	664-21667
29B	Pin, Lift (24/Pk'g.—6 Pins Req'd. Per Cyl. Ass'y.)	229-19841-800	229-19841-800	229-19841-800
29C	Spring (24/Pk'g.—6 Springs Req'd. Per Cyl. Ass'y.)	229-13487-800	229-13487-800	229-13487-800
29D	Ring, Retainer (12 Req'd. Per Cyl. Ass'y.)	029-09016	029-09016	029-09016
CYLINDER SLEEVE — NON-UNLOADING		 SEE FIGURE 10 FOR LOCATIONS		
Ⓢ 29 II	Sleeve Cylinder (No. Req'd. See Fig. 10)	664-21667	664-21667	664-21667

FIG. 6 — CYLINDER SLEEVE ASSEMBLY