

FIG. 13— CRANKCASE FLOAT

TABLE 13— CRANKCASE FLOAT

ITEM NO.	DESCRIPTION	PART NO.
	Crankcase Float	364-26809
	Includes:	
1	Cover, Handhole	064-26808
2	Adapter	064-26807
3	Valve Body	064-45531
4	Lever, Float	068-04542
5	Valve, Float	068-04545
6	Pin, Valve	068-01594
7	Pin, Lever	065-02071
8	Ball, Float	022-00530
9	Nut-Hex Self Locking	021-09610
10	Lockwasher	021-05273
11	Nut, Hex Jam	021-08073
12	Pin, Roll	029-08228

DESIGN HISTORY

Since the introduction of the J Series compressors, several design changes have been made to improve performance and/or reliability. These changes are described below. Be sure to read this section thoroughly before ordering renewal parts.

1. Driveline Components — Styles A, B & C compressors were equipped with a thrust collar at both ends of the compressor. Style D compressors are equipped with a thrust collar on the motor end only. On Style D compressors the pump end bearing housing has been increased in length to compensate for the elimination of the thrust collar on that end.

Crankshaft Part No's. listed are for Style D as these can also be used in Style A, B & C compressors. The Style D crankshaft can be used as a direct substitution in a Style C compressor (but not vice versa).

However, when substituting a Style D crankshaft in a Style A or B compressor, it is also necessary to replace original cast iron pistons with aluminum pistons. (See Para. #3). Style A, B & C crankshafts are no longer available.

Motor End bearing assembly Part No's. listed are for Style D. These can also be used in Style A, B or C; however an increase in oil pressure (approx. 20 lb. increase) will occur.

Pump End bearing assembly Part No's. are listed for Style A, B & C, and also for Style D. These parts are not interchangeable.

2. Unloader Sleeves, and Unloader Lift Pins — The length of the unloader sleeve and the length of the unloader lift pin have been changed on Style D compressors. See following sketch:

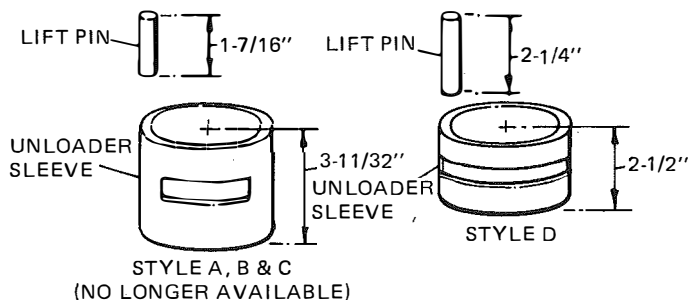

Unloader lift pins and unloader sleeves are no longer available for Style A, B or C compressors. If either the lift pins or the unloader sleeve must be replaced on a Style A, B or C compressor, both the lift pins and the unloader sleeve must be replaced with the Style D design.

3. Pistons — Style A & B compressors were equipped with cast iron pistons. Style C & D compressors are equipped with aluminum pistons. Cast iron and aluminum pistons cannot be mixed within a compressor due to the difference in weight. Also pistons must be used with the proper crankshaft. (See Paragraph 1.)