

WATERBOX GASKETS (CONT'D)

TABLE 44 - EVAPORATOR WITH STANDARD COMPACT WATERBOXES 300 PSI

SHELL CODE	1 PASS		2 PASS		3 PASS	
	GASKET P/N	FEET REQUIRED	GASKET P/N	FEET REQUIRED	GASKET P/N	FEET REQUIRED
AP-AS	028-03242-000	13.7'	028-09951-000 028-03242-000	2.2' 13.7'	028-09951-000 028-03242-000	3.9' 13.7'
CP-CS	028-03242-000	17.9'	028-09951-000	3'	028-09951-000	5.8'
DP-DS			028-03242-000	17.9'	028-03242-000	17.9'
EP-ET	028-03242-000	20.8'	028-09951-000	3.7'	028-09951-000	6.5'
FQ-FT			028-03242-000	20.8'	028-03242-000	20.8'
GQ-GS	028-03242-000	23.8'	028-09951-000	13.5'	028-09951-000	6.7'
HQ-HS			028-03242-000	23.8'	028-03242-000	23.8'
JP-JS	028-03242-000	26'	028-09951-000	4.5'	028-09951-000	8'
KP-KX			028-03242-000	26'	028-03242-000	26'
LQ-LS						
K2-K7	-	-	-	-	028-09951-000 028-03242-000	6.7' 23.8'
MQ-MS	028-03242-000	28'	028-09951-000	5'	028-09951-000	8'
M2-M4			028-03242-000	28'	028-03242-000	28'
NQ-NS						
N2-N4						
PQ-PS	028-03242-000	32.5'	028-09951-000	5.5'	028-09951-000	5.5'
P2-P4			028-03242-000	32.5'	028-03242-000	32.5'
QQ-QV						
Q2-Q4						

NOTE: When ordering Gasket Material specify length required by replacing the -000 with either -025 for 25', -050 for 50', or -100 for 100'.

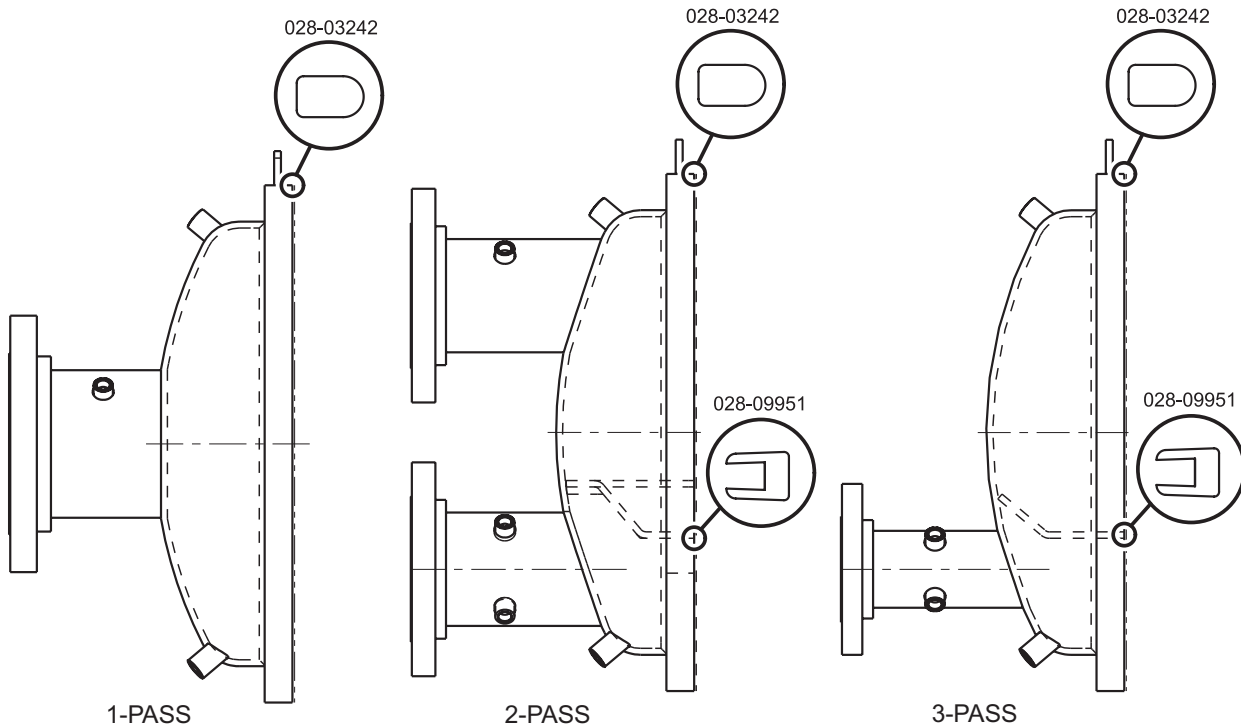

LD13149

FIGURE 46 - EVAPORATOR 300 LB. WATERBOX GASKET