

TABLE 70 - EVAPORATOR 300# MARINE WATERBOX (MOD C)

SHELL	1 PASS		2 PASS		3 PASS	
	GASKET P/N	FEET REQ'D	GASKET P/N	FEET REQ'D	GASKET P/N	FEET REQ'D
B, M	028 03242	60'	028 09951	11'	028 09951	18'
			028 03242	45'	028 03242	60'
N	028 03242	65'	028 09951	11'	028 09951	20'
			028 03242	49'	028 03242	65'
E	028 03242	76'	028 09951	24'	028 09951	24'
			028 03242	57'	028 03242	76'
F, G	028 03242	86'	028 09951	14'	028 09951	27'
			028 03242	65'	028 03242	86'
H, K	028 03242	92'	028 09951	15'	028 09951	29'
			028 03242	69'	028 03242	92'

NOTE:

When ordering Gasket Material specify length required by replacing the -000 with either -025 for 25', -050 for 50', or -100 for 100'.

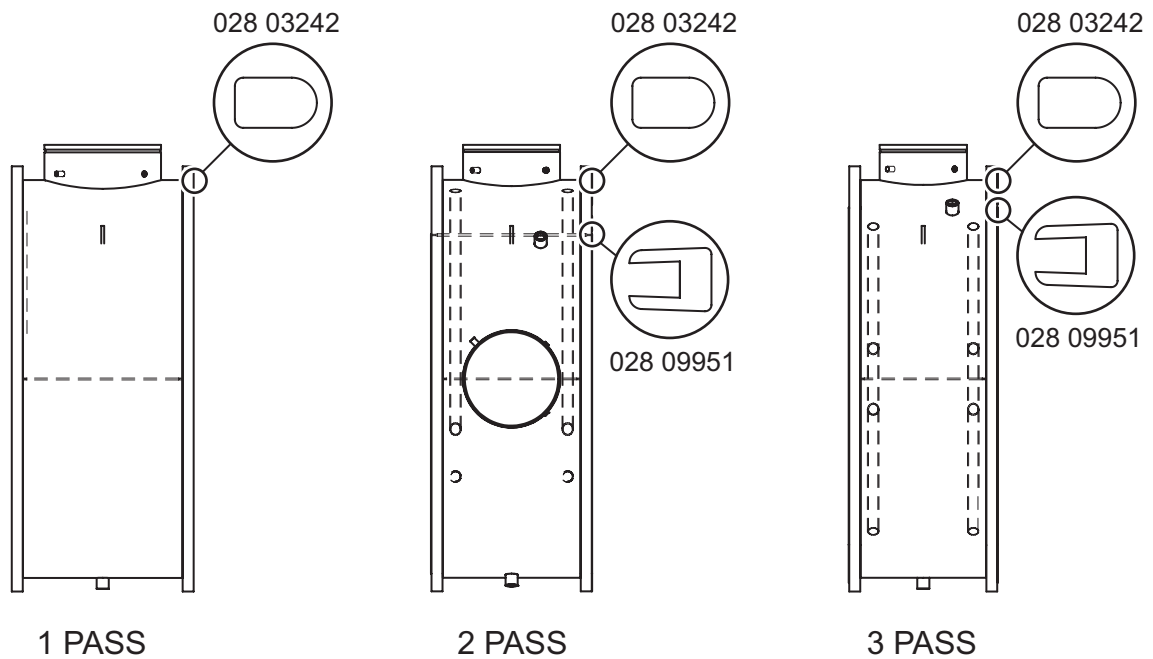

FIGURE 83 - EVAPORATOR 300# MARINE WATERBOX (MOD C)

LD15191