

EVAPORATOR COMPACT WATERBOX

TABLE 65 - EVAPORATOR 150# COMPACT WATERBOX (MOD C)

SHELL	1 PASS		2 PASS		3 PASS	
	GASKET P/N	FEET REQ'D	GASKET P/N	FEET REQ'D	GASKET P/N	FEET REQ'D
B, M	028 03242	30'	028 09951	6'	028 09951	10'
			028 03242	30'	028 03242	30'
N	028 03242	32'	028 09951	6'	028 09951	11'
			028 03242	32'	028 03242	32'
E	028 03242	38'	028 09951	6'	028 09951	12'
			028 03242	38'	028 03242	38'
F, G	028 03242	43'	028 09951	7'	028 09951	14'
			028 03242	43'	028 03242	43'
H, K	028 03242	46'	028 09951	8'	028 09951	15'
			028 03242	46'	028 03242	46'

NOTE:

When ordering Gasket Material specify length required by replacing the -000 with either -025 for 25', -050 for 50', or -100 for 100'.

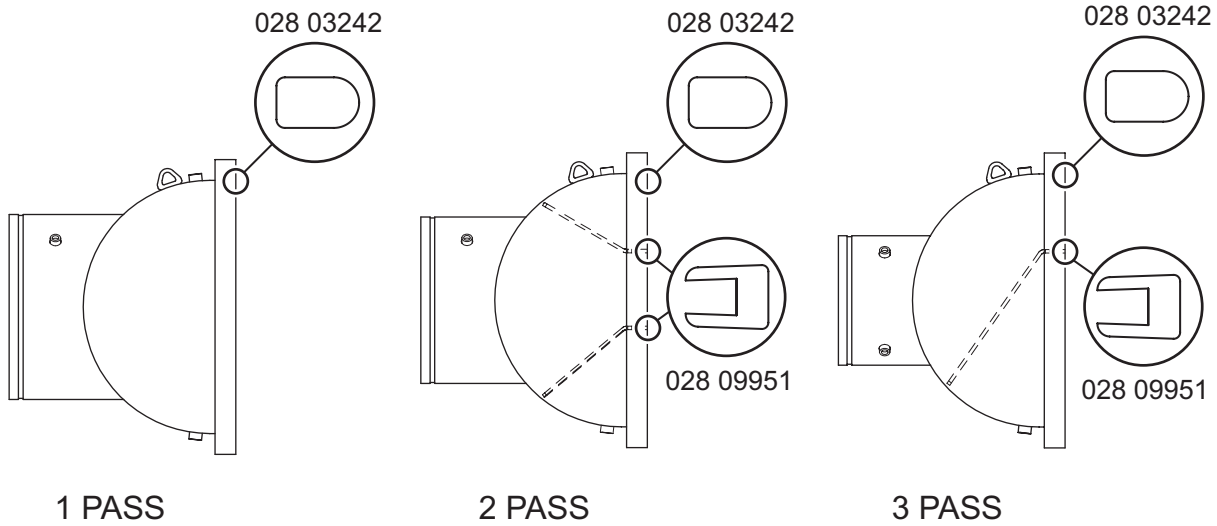

LD15188

FIGURE 78 - EVAPORATOR 150# COMPACT WATERBOX (MOD C)