

TABLE 64 - CONDENSER 300# MARINE WATERBOX (MOD B)

| SHELL | 1 PASS | | 2 PASS | | 3 PASS | |
|-------|------------|------------|------------|------------|------------|------------|
| | GASKET P/N | FEET REQ'D | GASKET P/N | FEET REQ'D | GASKET P/N | FEET REQ'D |
| B | 028 03242 | 56' | 028 09951 | 9' | 028 09951 | 18.25' |
| | | | 028 03242 | 42' | 028 03242 | 60' |
| C | 028 03242 | 56' | 028 09951 | 9.5' | 028 09951 | 18.25' |
| | | | 028 03242 | 45' | 028 03242 | 60' |
| D/E | 028 03242 | 56' | 028 09951 | 9.5' | 028 09951 | 19.5' |
| | | | 028 03242 | 45' | 028 03242 | 66' |
| F/G | 028 03242 | 56' | 028 09951 | 11' | 028 09951 | 22' |
| | | | 028 03242 | 52.5' | 028 03242 | 70' |
| H/K | 028 03242 | 56' | 028 09951 | 11' | 028 09951 | 22' |
| | | | 028 03242 | 52.5' | 028 03242 | 70' |

NOTE:

When ordering Gasket Material specify length required by replacing the -000 with either -025 for 25', -050 for 50', or -100 for 100'.

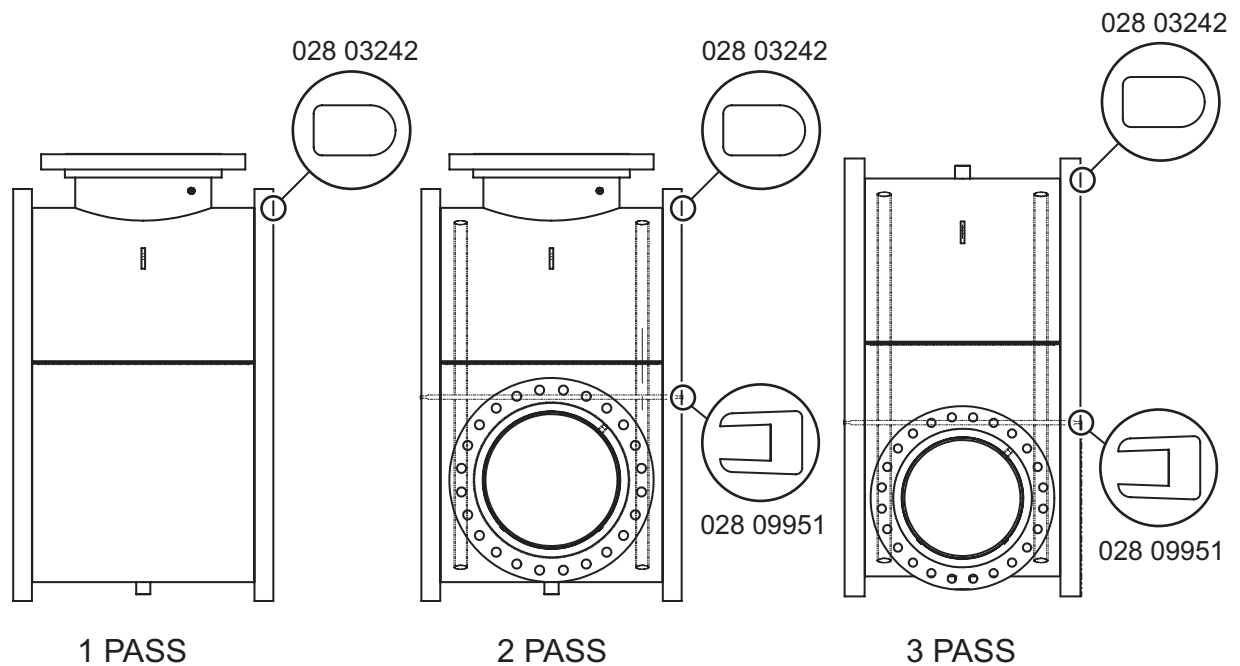

FIGURE 77 - CONDENSER 300# MARINE WATERBOX (MOD B)

LD15387