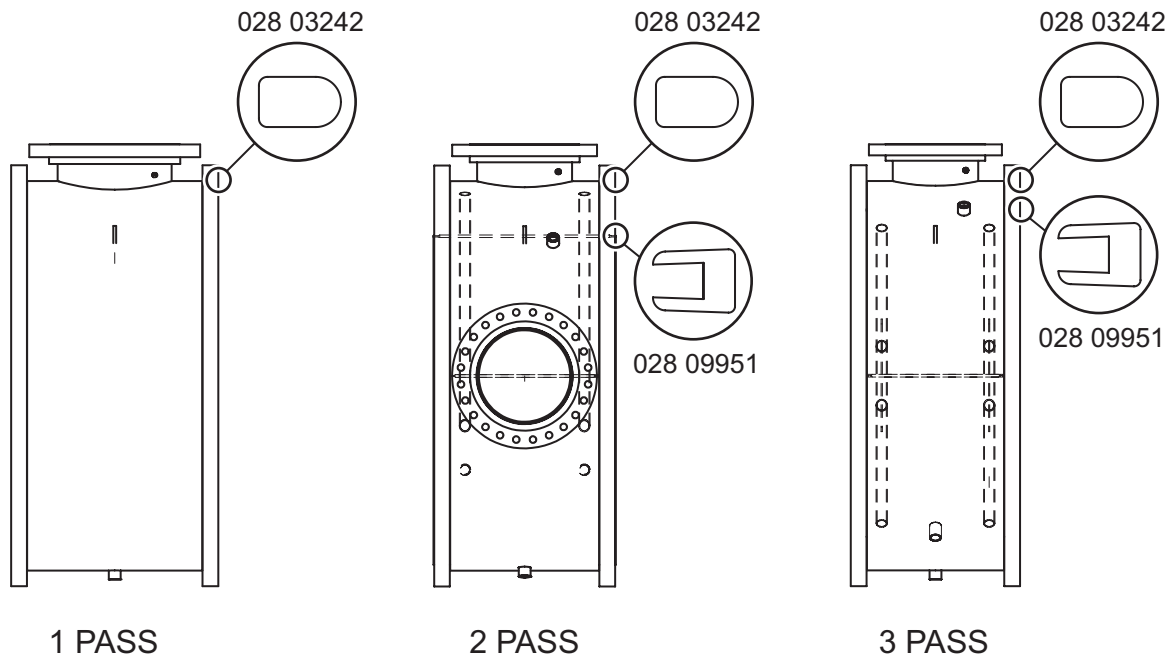

**TABLE 62 - EVAPORATOR 300# MARINE WATERBOX (MOD B)**

SHELL	1 PASS		2 PASS		3 PASS	
	GASKET P/N	FEET REQ'D	GASKET P/N	FEET REQ'D	GASKET P/N	FEET REQ'D
<b>B</b>	028 03242	76'	028 09951	23.5'	028 09951	23.5'
			028 03242	57'	028 03242	76'
<b>C</b>	028 03242	76'	028 09951	23.5'	028 09951	23.5'
			028 03242	57'	028 03242	76'
<b>D/E</b>	028 03242	76'	028 09951	23.5'	028 09951	23.5'
			028 03242	57'	028 03242	76'
<b>F/G</b>	028 03242	76'	028 09951	23.5'	028 09951	26.5'
			028 03242	57'	028 03242	86'
<b>H/K</b>	028 03242	76'	028 09951	23.5'	028 09951	26.5'
			028 03242	57'	028 03242	86'

**NOTE:**

When ordering Gasket Material specify length required by replacing the -000 with either -025 for 25', -050 for 50', or -100 for 100'.



**FIGURE 75 - EVAPORATOR 300# MARINE WATERBOX (MOD B)**

LD15191