

TABLE 58 - EVAPORATOR 300# COMPACT WATERBOX (MOD B)

SHELL	1 PASS		2 PASS		3 PASS	
	GASKET P/N	FEET REQ'D	GASKET P/N	FEET REQ'D	GASKET P/N	FEET REQ'D
B	028 03242	38'	028 09951	6'	028 09951	12'
			028 03242	38'	028 03242	38'
C	028 03242	38'	028 09951	6'	028 09951	12'
			028 03242	38'	028 03242	38'
D/E	028 03242	38'	028 09951	6'	028 09951	12'
			028 03242	38'	028 03242	38'
F/G	028 03242	38'	028 09951	6'	028 09951	14'
			028 03242	38'	028 03242	43'
H/K	028 03242	38'	028 09951	6'	028 09951	14'
			028 03242	38'	028 03242	43'

NOTE:

When ordering Gasket Material specify length required by replacing the -000 with either -025 for 25', -050 for 50', or -100 for 100'.

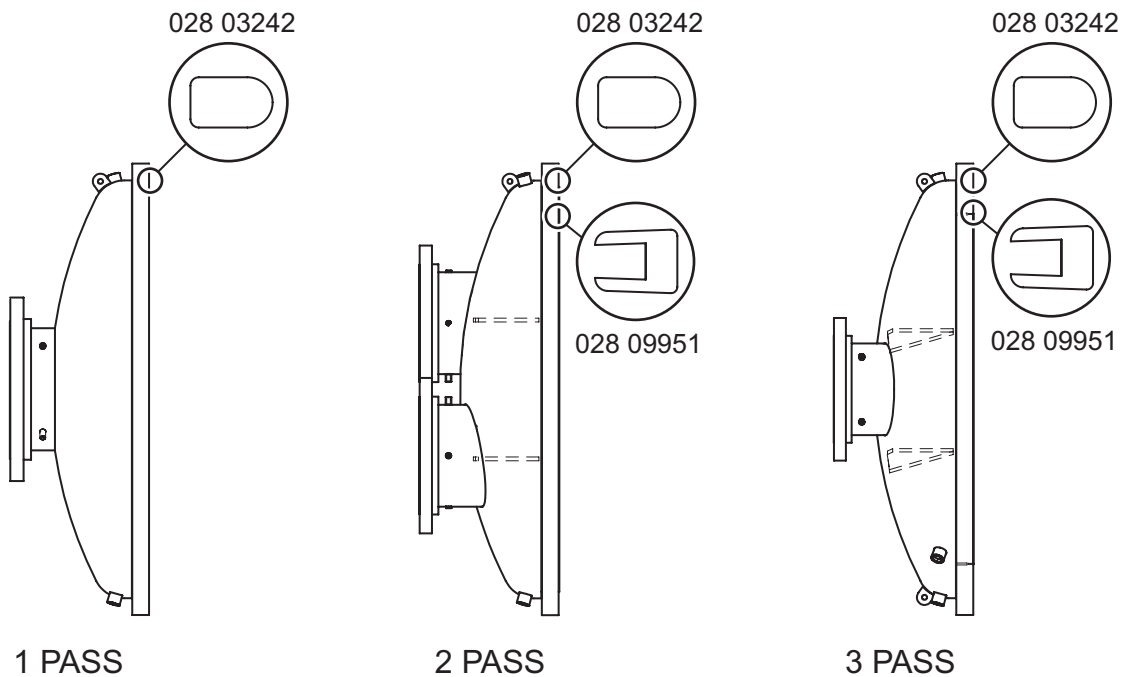

FIGURE 71 - EVAPORATOR 300# COMPACT WATERBOX (MOD B)