

OIL PUMP & MOTOR ASSEMBLIES

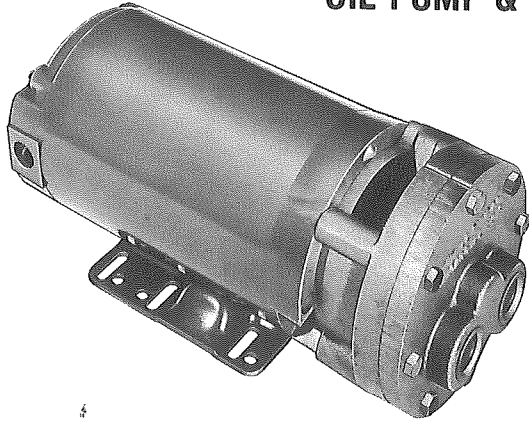

OIL PUMP SEAL KIT — Part No. 026-20340
OIL PUMP HOUSING O-RING — Part No. 028-09577

Voltage	Complete Motor & Pump Assembly			Replacement Motors			Replacement Oil Pumps
	Part No. Standard (Nema 1)	Part No. Nema 4 & 7	Part No. TEFC	Part No. Standard (Nema 1)	Part No. Nema 6 & 7	Part No. TEFC	Part No.
208-3-60	026-20166			024-18565			026-20341
220/440, 230/460, 240/480-3-60	026-20165	026-20940	026-20170	024-18562	024-18564	024-18563	026-20341
550/575/600-3-60	026-20167			024-18566			026-20341
190/380-3-50	026-20168	026-20941	026-20171	024-18567	024-18569	024-18568	026-20341
415-3-50	026-20169	026-20908		024-18570			026-20341

FIG. 15 — OIL PUMP & MOTOR ASSEMBLY

CONTROLS

Description	Part No.	Quan.
High Oil Temperature (Hot)	025-15381-003	1
High Discharge Temperature Control (HDTC)	025-15381-002	1

OIL HEATERS

Watts	Volts	NEMA	Part No.
1500	120	1	025-17700
1500	240	1	025-17787
1500	120	4 & 7	025-17701
2500	120	4 & 7	025-16703
2500	480	4 & 7	025-15977
2500	277	1	025-16212
2500	480	1	025-16298
2500	550	1	025-16950-900
2500	120	1	025-16137

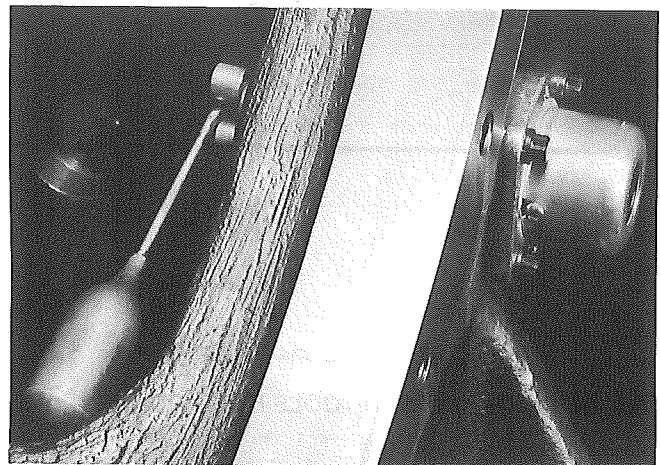

FLOAT SWITCH OIL RETURN

Part No.
025- 19856

LUBRICANTS, OILS AND COMPOUNDS

Description	Part No.
Thread Compound, Air High Pressure—1/4 Pt. Can	464-14934
Coating Lubricant-Molykote, Type Z—2 Oz. Can	364-21508
Oil, York Refrigeration-Type B,—5 Gal. Can	011-00309