

FIG. 4 – TURBOPAK SYSTEM DETAILS

STANDARD ISOLATION MOUNT

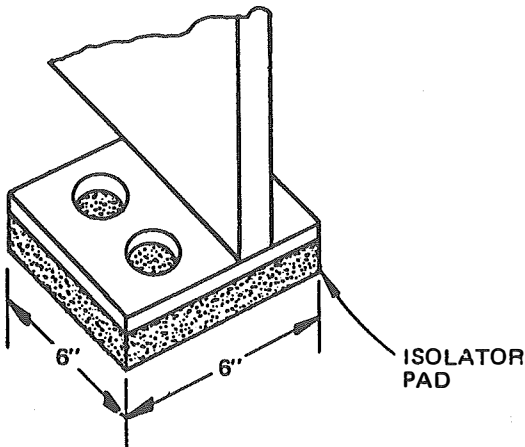

FIG. 5 – (STANDARD) VIBRATION ISOLATION MOUNTS – PART NO. 028-10519

OPTIONAL SPRING ISOLATORS

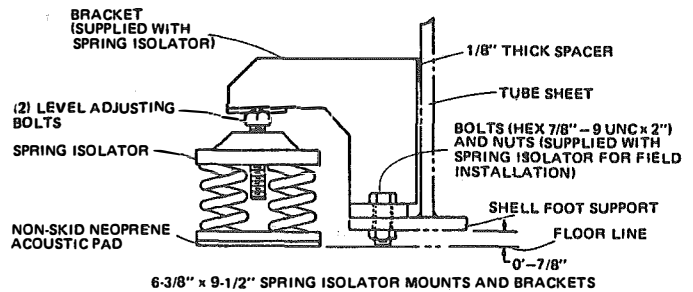

FIG. 6 – OPTIONAL SPRING ISOLATORS – PART NO. 029-18114-002