

VANES & MOTOR ARE TO BE IN CLOSED POSITION WHEN ASSEMBLING.

TURN NUT ON SHAFT TO ALLOW 1" THREAD ENGAGEMENT WITH CLEVIS.

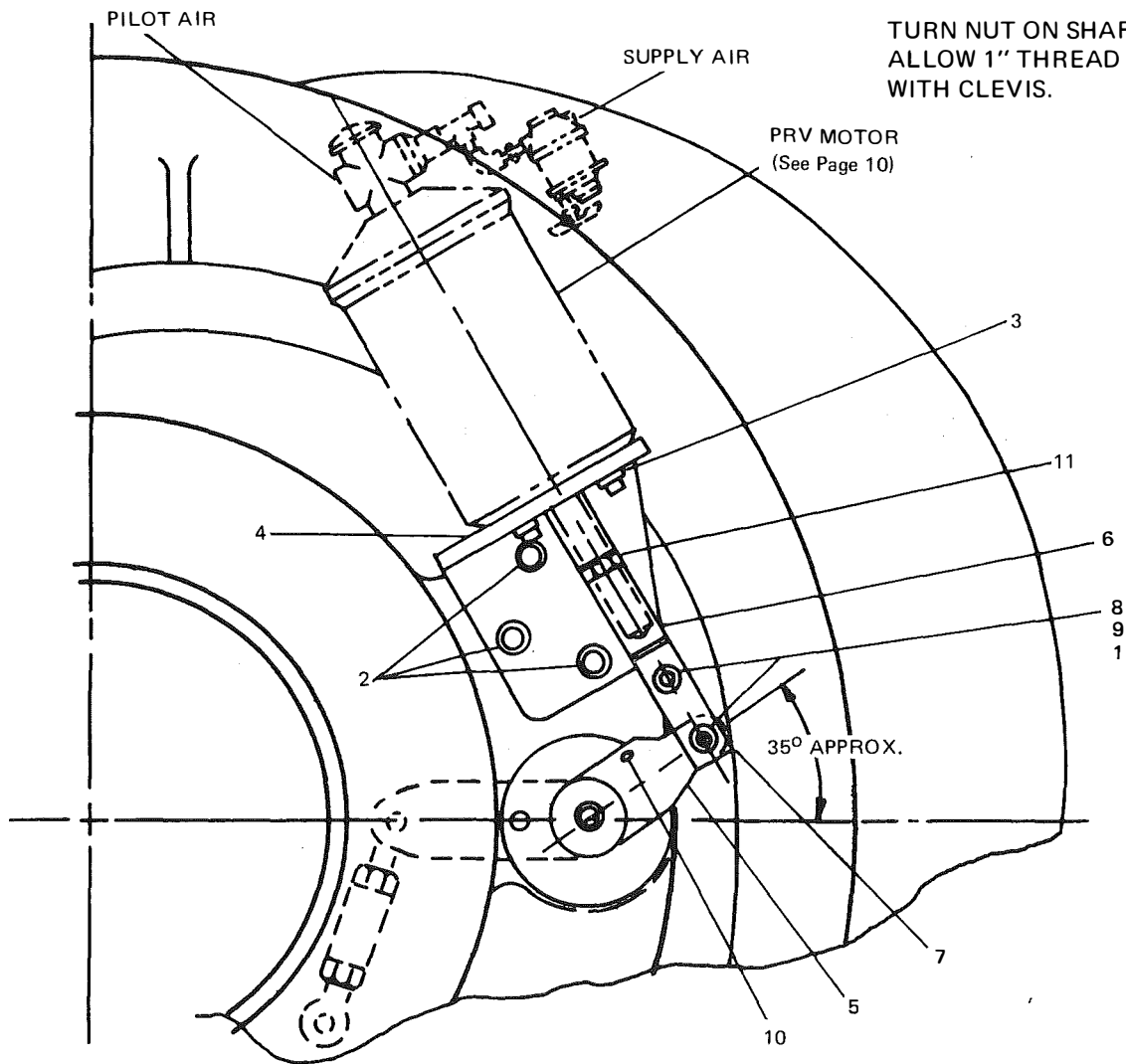

Item	Description	Quan.	Part No.
1	Cot. Pin 3/32 Dia. X 3/4 Lg.	4	021-01083
2	Screw Cap 12 Pt. Hd. 3/8-16 UNC-3A X 1-3/8 Lg.	3	021-11986
3	Screw Cap 12 Pt. Hd. 3/8-16 UNC X 3A X 1-1/4 Lg.	4	021-11141
4	Bracket, Mounting	1	064-27596
5	Lever	1	064-25791
6	Clevis	1	064-07125
7	Link	2	064-25792
8	Pin 3/8 Dia. X 1-1/2 Lg.	2	064-07127
9	Washer, 13/32 I.D. X 13/16 O.D.	4	021-01274
10	Pin Insert 3/32 Dia. X 1-1/8 Lg.	1	029-05900
11	Nut, Hex, Heavy 5/8-18UNF	1	021-07787

FIG. 9-PRV ELECTRONIC EXTERNAL LINKAGE