

**MODELS LTD67 AND LTD76  
LINKAGE - EXTERNAL PRV  
ELECTRICALLY OPERATED**

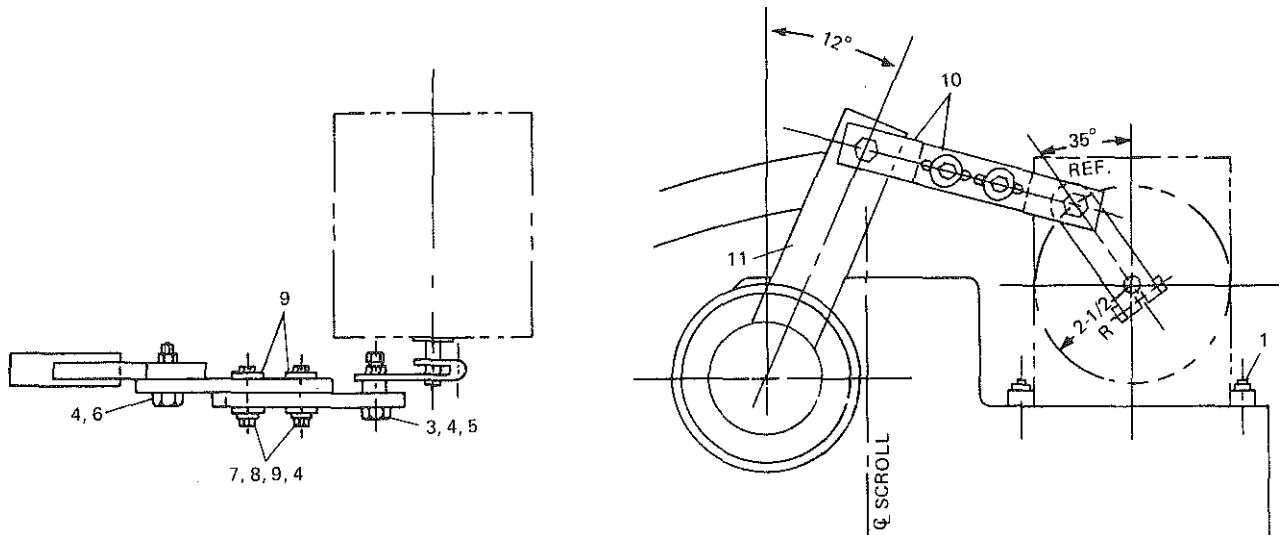

**FIG. 16 – LINKAGE EXTERNAL PRV – ELECTRICALLY OPERATED**

ITEM	PART DESCRIPTION	QUAN.	PART NO.
1	SCREW, CAP, 1/4-20UNC x 3/4 LG.	3	021-11741
2	ARM, CRANK PRV	1	025-17073
3	BOLT, SHLD. 1/4-20 x 1-5/8	1	064-28286
4	NUT, HEX. 1/4-20UNC-2B	6	021-00450
5	RING, STL. 5/8 O.D. x 17/64 I.D. x 1/2 LG.	1	064-28284
6	BOLT, SHLD. 1/4-20 x 1-3/8	1	064-28262
7	SCREW, CAP. 1/4-20UNC x 1 LG.	2	021-11914
8	LOCKWASHER 1/4	2	021-05267
9	WASHER 9/32 I.D.	4	021-05165
10	LINK, EXT. PRV & MOT.	2	064-28260
11	LEVER, PRV DEVICE	1	364-28236

**AIR OPERATED**

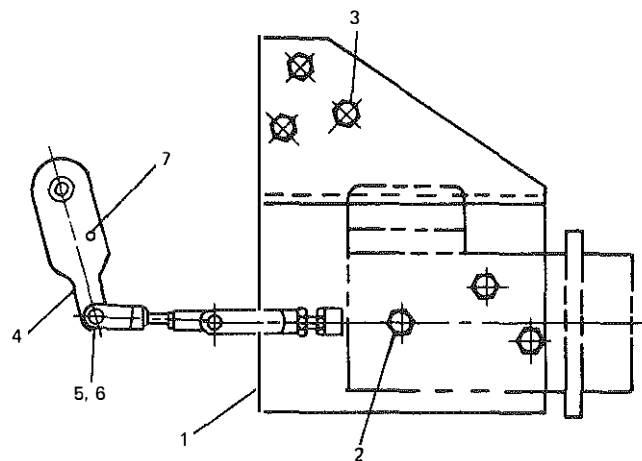

**FIG. 17 – LINKAGE EXTERNAL PRV – AIR OPERATED (PNEUMATIC)**

ITEM	PART DESCRIPTION	QUAN.	PART NO.
1	BRACKET, PRV MOTOR MOUNTING	1	064-20428
2	SCREW, CAP, HEX. HD. 1/4-20UNC x 5/8 LG.	3	021-01372
3	SCREW, CAP, HEX. HD. 1/2-13UNC x 7/8 LG.	3	021-02750
4	LEVER, PRV DEVICE	1	064-16836
5	SCREW, CAP, 1/4-20UNC x 1-1/2 LG.	1	021-02399
6	NUT, HEX. HD. 1/4-20UNC	2	021-00450
7	PIN, INSERT	1	029-05900