

**MODELS LTD53 AND LTD59
LINKAGE - EXTERNAL PRV
ELECTRICALLY OPERATED**

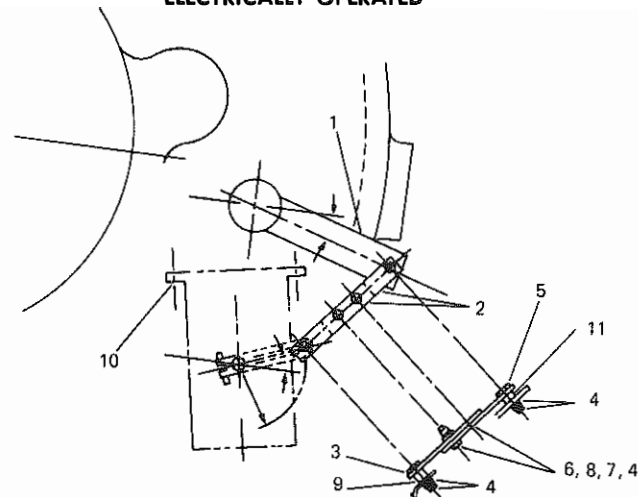

FIG. 7— LINKAGE EXTERNAL PRV – ELECTRICAL OPERATED

ITEM	PART DESCRIPTION	QUAN.	PART NO.
1	LEVER, PRV DEVICE	1	364-28236
2	LINK, EXT. PRV	2	064-28260
3	BOLT SHOULDER	1	064-28286
4	NUT, HEX, 1/4-20UNC	6	021-00450
5	BOLT SHOULDER	1	064-28282
6	SCREW, CAP HEX HD.	2	021-11914
7	LOCKWASHER, 1/4	2	021-05267
8	WASHER, PLAIN	2	021-05165
9	RING, 5/8 O.D. x 17/64 x 1/2 LG.	1	064-28284
10	SCREW, CAP 12 PT. HD.	3	021-11741
11	RING, 5/8 OD x 17/64 x 3/8 LG.	1	064-28353
12	ARM, CRANK	1	025-17073

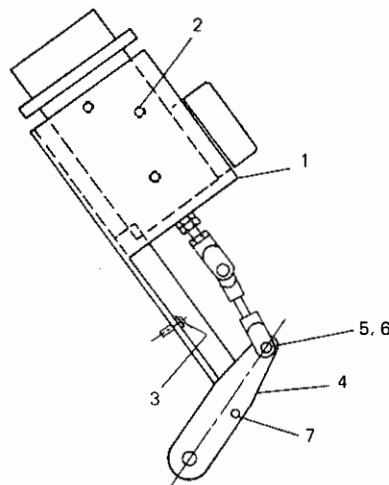

FIG. 8— LINKAGE – EXTERNAL PRV – AIR OPERATED (PNEUMATIC)

ITEM	PART DESCRIPTION	QUAN.	PART NO.
1	BRACKET, MOUNTING PRV MOTOR	1	364-16838
2	SCREW, CAP, 1/4-20UNC x 5/8	3	021-01372
3	SCREW, CAP, 5/16-18UNC x 3/4	4	021-11394
4	LEVER – PRV DEVICE	1	064-17898
5	SCREW, CAP, 1/4-20UNC x 1-1/2	1	021-02399
6	NUT – HEX, 1/4-20UNC	2	021-00450
7	PIN, INSERT	1	029-04842