

LINKAGE - EXTERNAL PRV
ELECTRICALLY OPERATED

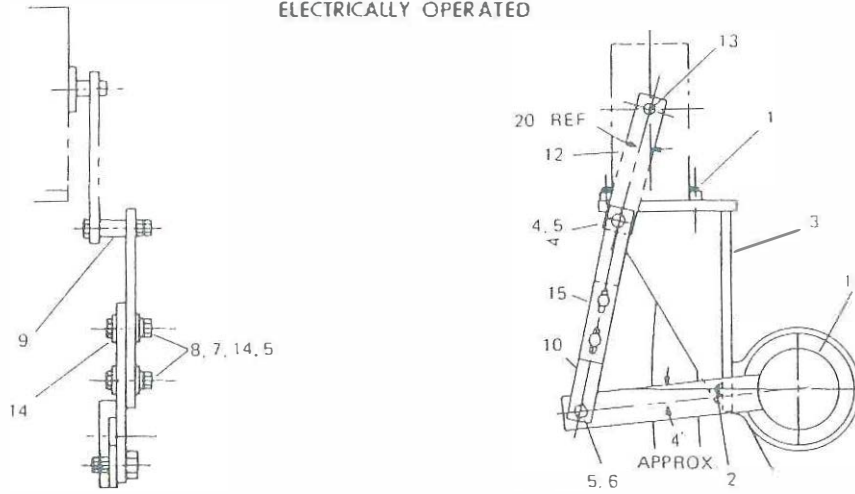

FIG. 34— LINKAGE EXTERNAL - PRV - ELECTRICALLY OPERATED

ITEM	PART DESCRIPTION	QUAN.	PART NO.
1	SCREW, CAP. 1/4 - 20UNC x 3/4 LG.	3	021-11741
2	SCREW, CAP. 3/4 - 16UNC x 7/8 LG.	2	021-11139
3	BRACKET, MOTOR MOUNTING	1	364-32574
4	BOLT, SHLD. 1/4 - 20 x 1-7/8 LG.	1	064-33745
5	NUT, HEX 1/4 - 20UNC - 2B	6	021-00450
6	BOLT, SHLD. 1/4 - 20 x 1-3/8	1	064-28262
7	LOCKWASHER 1/4	2	021-05267
8	SCREW, CAP. 1/4 - 20UNC x 1 LG.	2	021-11914
9	RING, 5/8 OD x 17/64 ID x 1/2	1	064-28284
10	LINK, EXT. PRV & MOT.	1	064-28261
11	LEVER, PRV DEVICE	1	364-28252
12	ARM, MOTOR PRV	1	064-33689
13	SCREW, SET HEX. SEC. = 10 - 24UNC x 3/8	1	021-03910
14	WASHER 9/32 I.D.	4	021-05165
15	LINK, EXT. PRV & MOT.	1	064-32570

AIR OPERATED

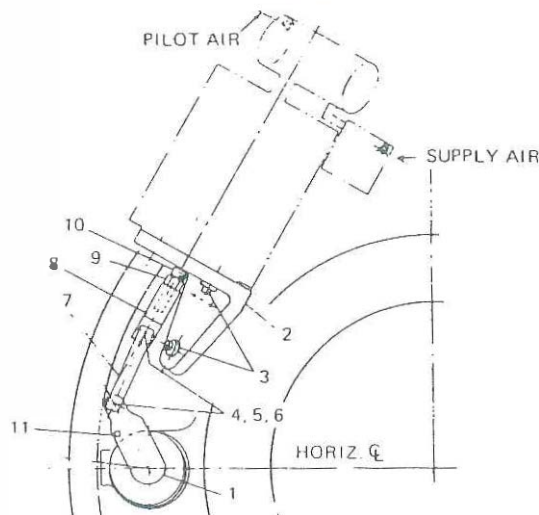

FIG. 35— LINKAGE EXTERNAL - PRV - AIR OPERATED (PNEUMATIC)

ITEM	PART DESCRIPTION	QUAN.	PART NO.
1	LEVER, PRV DEVICE	1	064-28626
2	BRACKET	1	064-28625
3	SCREW, CAP. 12 PT 1/2 x 1-1/2	7	021-11933
4	PIN, LINKAGE	2	064-07127
5	WASHER, PLAIN 13/32	4	021-01274
6	PIN, COTTER	4	021-01083
7	LINKAGE	2	064-29618
8	CLEVIS, CONOMOTOR	1	064-29619
9	NUT, HEX JAM 3/4 UNF	1	021-00591
10	WASHER, PLAIN 13/16	6	021-05157
11	PIN INSERT 3/32 x 1 1/8	1	029-05900