

ITEM	PART DESCRIPTION	MODELS											
		OT 90 THRU OT 130			OT 150 THRU OT 230			OT 260 THRU OT 350			OT 390 THRU OT 600		
		PART NO.	QUAN.	FIG.	PART NO.	QUAN.	FIG.	PART NO.	QUAN.	FIG.	PART NO.	QUAN.	FIG.
1	GLASS, SIGHT 4"	026-09608	2	51	026-09608	3	52	026-09608	3	52	026-09608	2	53
2	GLAND, SIGHT GLASS 4"	067-27590	2	51	067-27590	3	52	067-27590	3	52	067-27590	2	53
3	GASKET, SIGHT GLASS 4"	070-16406	4	51	070-16406	6	52	070-16406	6	52	070-16406	4	53
4	GLASS, SIGHT - 1 1/2"	026-14298	1	51	—	—	—	—	—	—	026-14298	2	53
5	GASKET, BULB 3/8	028-03242	*	51	028-03242	*	52	028-03242	*	52	028-03242	*	53
6	GASKET FLOAT CHAMBER	067-77587	1	—	067-77587	1	52	067-77587	1	52	028-08016	1	53
7	FLOAT VALVE	—	—	—	367-77632	2	54	367-77632	2	54	367-78820	1	54
8	STEM ADJUSTER	—	—	—	067-35393	1	54	067-35393	1	54	067-35393	1	54
9	WASHER PACKING	—	—	—	068-00050	2	54	068-00050	2	54	068-00050	2	54
10	PACKING STEM	—	—	—	028-01100	1	54	028-01100	1	54	028-01100	1	54
11	NUT PACKING	—	—	—	068-00045	1	54	068-00045	1	54	068-00045	1	54
12	GASKET	—	—	—	028-01054	1	54	028-01054	1	54	028-01054	1	54
13	CAP VALVE	—	—	—	068-00034	1	54	068-00034	1	54	068-00034	1	54
14	FLOW RESTRICTOR	SEE TABLE 12	1	56	—	—	—	—	—	—	—	—	—
15	GASKET BULB 1/4"	SEE TABLE 11	—	—	—	—	—	—	—	—	028-07154	6 FT.	53

* TABLE 11— BULB GASKET - 028-03242 -
QUAN. PER UNIT

MODELS - OT	QUAN.
90 THRU 130	24 FT.
150 THRU 170	22 FT.
200 THRU 230	26 FT.
260	27 FT.
290	28 FT.
320	29 FT.
350	31 FT.
390 THRU 430	34 FT.
470 THRU 510	36 FT.
560 THRU 600	39 FT.

TABLE 12 — FLOW RESTRICTOR PLATES

MODELS-OT	PART NO.
90	066-14776-001
100	066-14776-002
110	066-14776-003
120	066-14776-004
130	066-14776-005

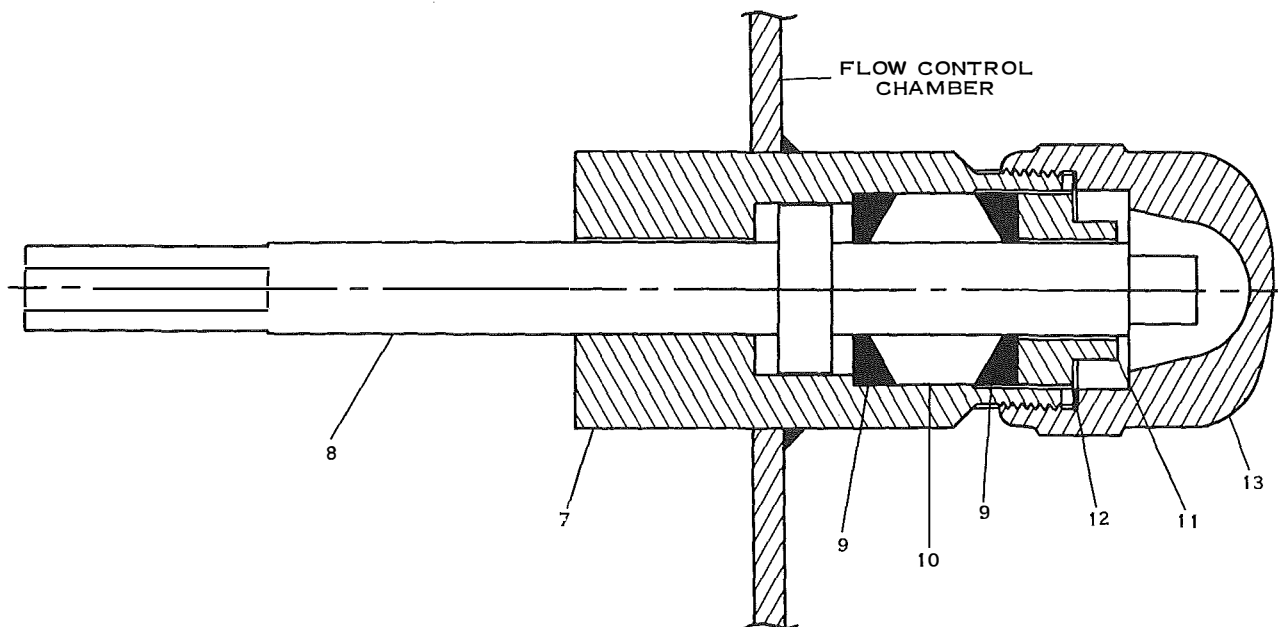

FIG. 54— Float Valve Adjuster - Models OT150 thru OT600