

MODELS LTD67 AND LTD76
LINKAGE - EXTERNAL PRV
ELECTRICALLY OPERATED

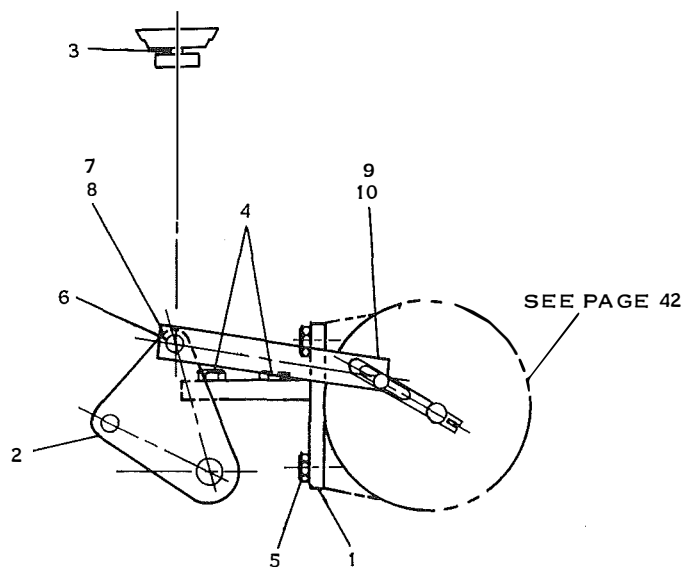

FIG. 25— Linkage External PRV - Electrically Operated

| ITEM | PART DESCRIPTION | QUAN. | PART NO. |
|------|---|-------|-----------|
| 1 | PLATE, MOTOR SUPPORT | 1 | 364-12236 |
| 2 | LEVER, PRV DEVICE | 1 | 064-12237 |
| 3 | TUBE, FILL PIECE | 1 | 064-15003 |
| 4 | SCREW, CAP, HEX. HD. $\frac{3}{8}$ -16UNC X 1 LG. | 3 | 021-11149 |
| 5 | SCREW, CAP, HEX. HD. $\frac{1}{4}$ -20UNC X $\frac{3}{4}$ LG. | 4 | 021-11741 |
| 6 | SCREW, CAP, HEX. HD. $\frac{3}{8}$ -16UNC X 2 $\frac{3}{4}$ LG. | 1 | 021-11940 |
| 7 | NUT, HEX. $\frac{3}{8}$ -16UNC | 2 | 021-00466 |
| 8 | LINK, EXT. PRV MOTOR | 1 | 064-12235 |
| 9 | BOLT SHOULDER (SPECIAL) | 1 | 064-12815 |
| 10 | NUT, HEX. $\frac{1}{4}$ -20UNC | 2 | 021-00450 |

AIR OPERATED

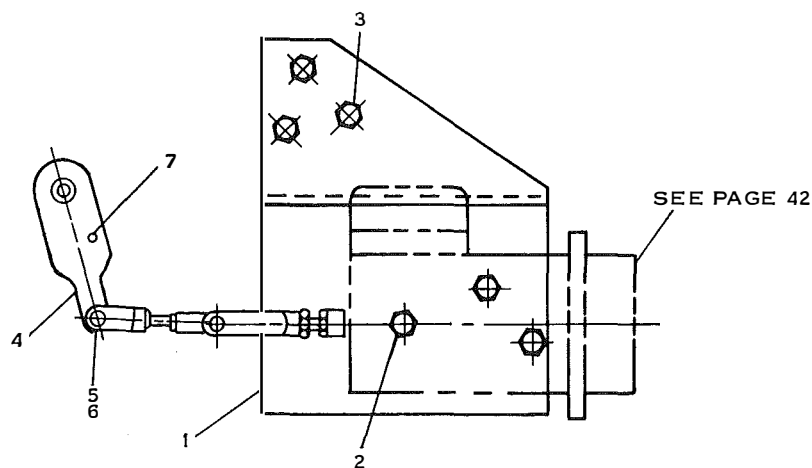

FIG. 26— Linkage External PRV - Air Operated

| ITEM | PART DESCRIPTION | QUAN. | PART NO. |
|------|---|-------|-----------|
| 1 | BRACKET, PRV MOTOR MOUNTING | 1 | 064-20428 |
| 2 | SCREW, CAP, HEX. HD. $\frac{1}{4}$ -20UNC X $\frac{5}{8}$ LG. | 3 | 021-08310 |
| 3 | SCREW, CAP, HEX. HD. $\frac{1}{2}$ -13UNC X $\frac{7}{8}$ LG. | 3 | 021-02750 |
| 4 | LEVER, PRV DEVICE | 1 | 064-16836 |
| 5 | SCREW, CAP, $\frac{1}{4}$ -20UNC X 1 $\frac{1}{2}$ LG. | 1 | 021-02399 |
| 6 | NUT, HEX. HD. $\frac{1}{4}$ -20UNC | 2 | 021-00450 |
| 7 | PIN, INSERT | 1 | 029-05900 |