

COOLERS AND CONDENSERS

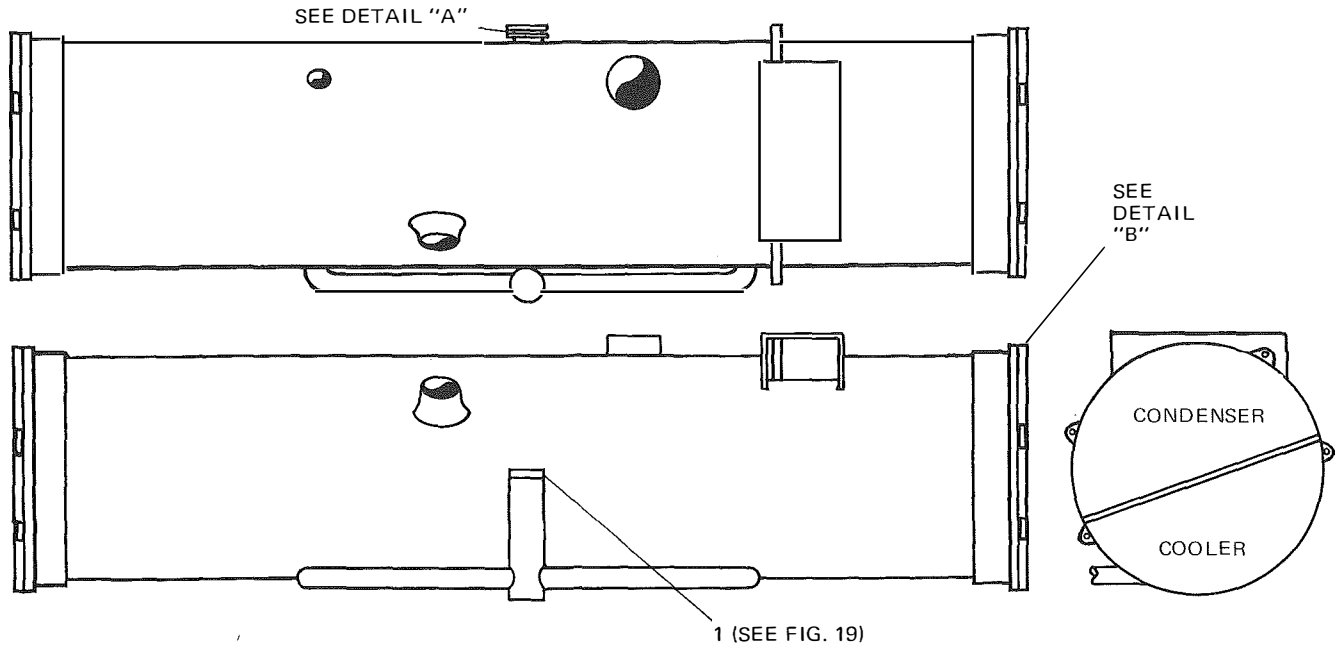

Item	Part Description	Part No.	Quan.	Fig.
1	Gasket, Orifice Plate	066-53619	1	1 (Det. A)
2	Gland, Sight Glass	067-27590	1	1 (Det. A)
3	Gasket, Sight Glass	070-16406	2	1 (Det. A)
4	Glass, Sight	026-09608	1	1 (Det. A)
5	Gasket, Bulb	028-03242	*	1 (Det. B)
6	Nut, Hex Hvy. 3/8	021-14232	14	1 (Det. A)
7	Screw Mach Flat Slot No. 10 X 1/2	021-10119	2	1 (Det. A)

FIG. 1— COOLER—CONDENSER SHELL

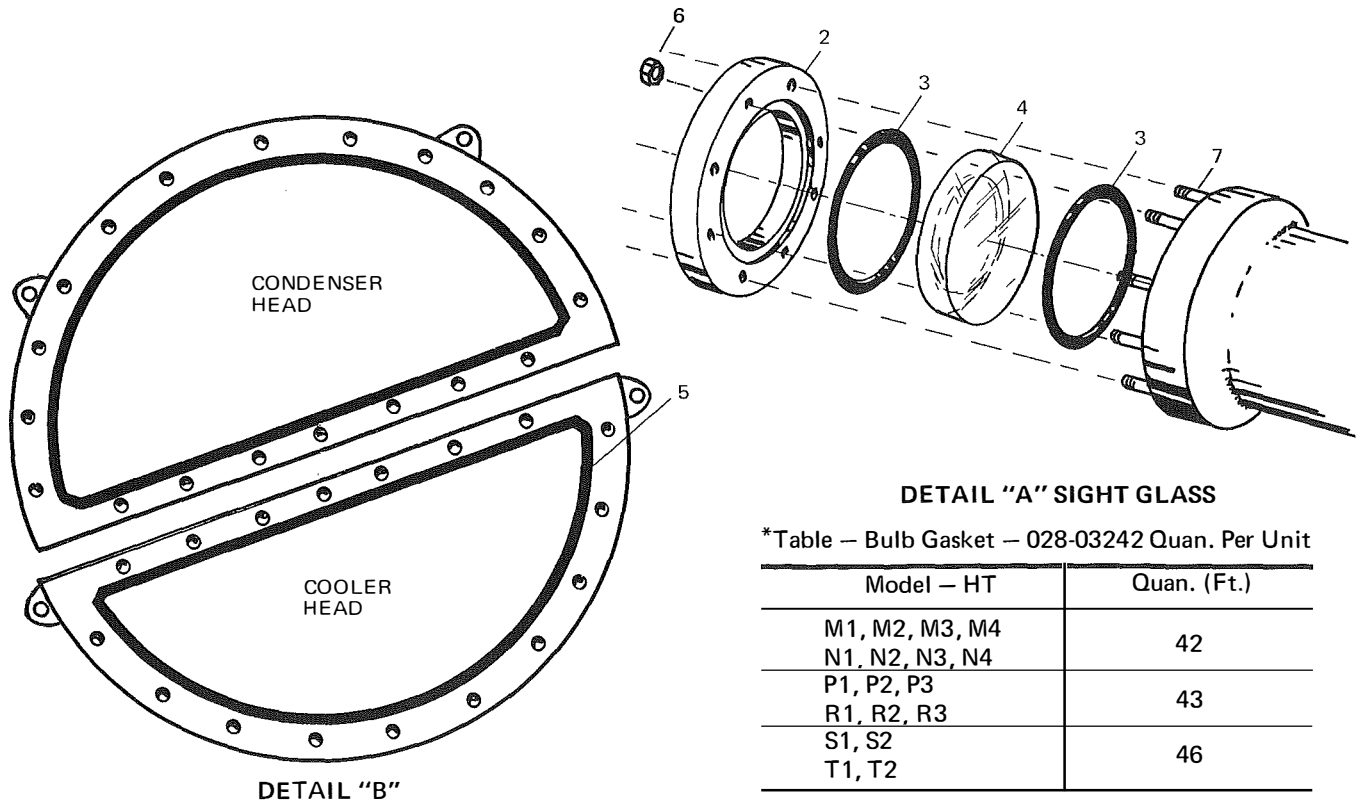

DETAIL "A" SIGHT GLASS

*Table — Bulb Gasket — 028-03242 Quan. Per Unit

Model — HT	Quan. (Ft.)
M1, M2, M3, M4 N1, N2, N3, N4	42
P1, P2, P3 R1, R2, R3	43
S1, S2 T1, T2	46