

ISOLATORS NEOPRENE

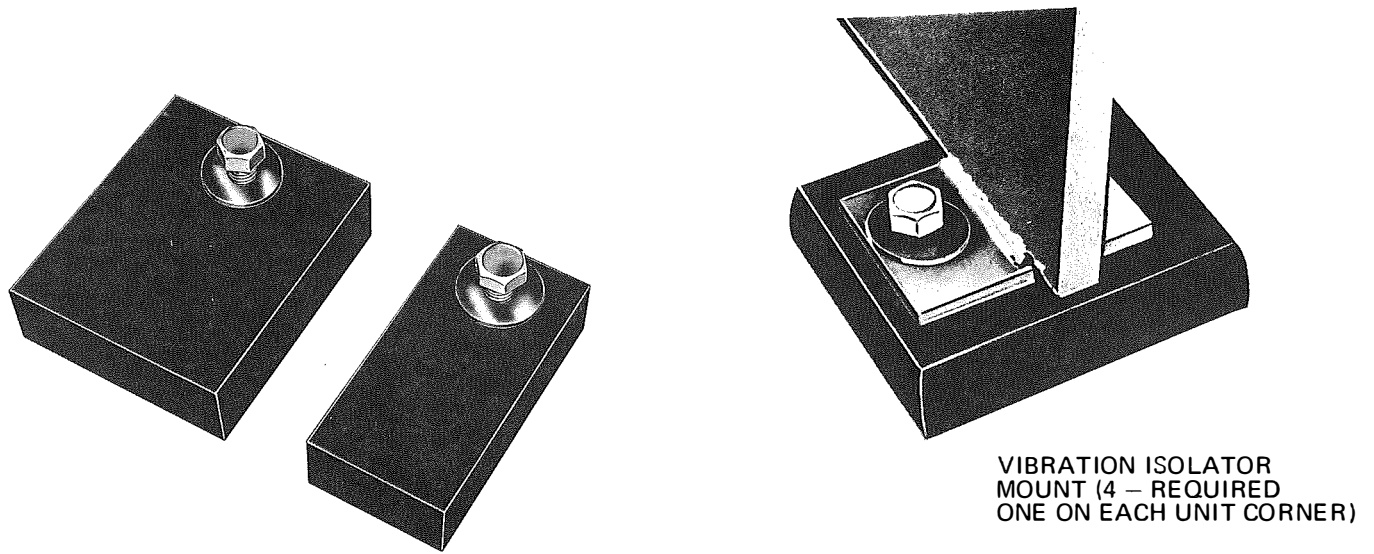

TURBOPAK OPERATING WEIGHT	ISOLATOR PART NO.
UP TO 16,700 LBS.	028-09254
16,701 TO 33,455 LBS.	028-09253

FIG. 8 - STANDARD VIBRATION ISOLATOR MOUNTS (MODELS HT/OT A1 A1 B1 THRU F3 S3 C2)

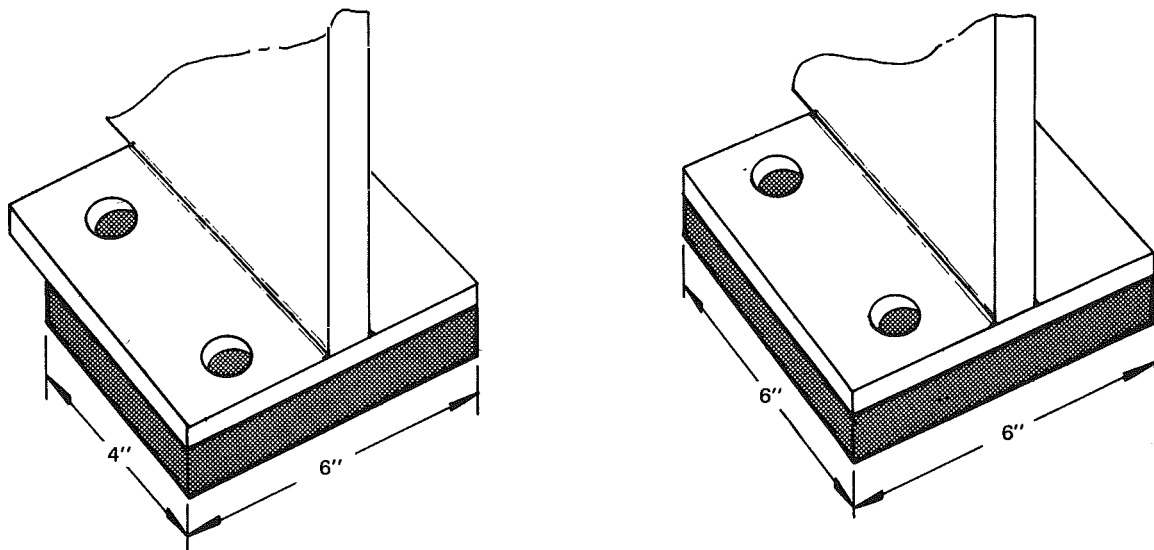

TURBOPAK OPERATING WEIGHT	ISOLATOR PART NO.
UP TO 28,835 LBS.	028-10518
28,836 TO 53,530 LBS.	028-10519

FIG. 9 - MODEL YT G1 G1 E1 THRU L3 X3 E3