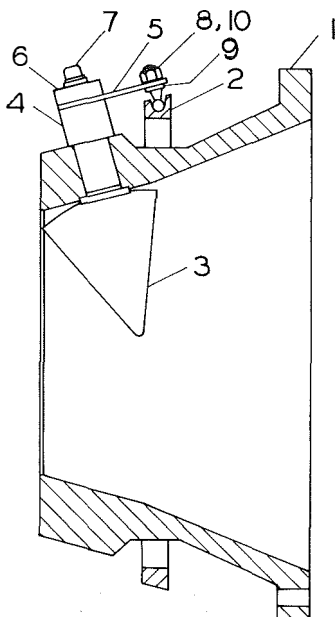

FIG. 8- Air Motor



ITEM	PART NO.	QUAN.	DESCRIPTION
1	064-13486	1	HOUSING - PRE-ROTATION (T67)
	064-13485		HOUSING - PRE-ROTATION (T76)
2	064-10815	1	RING - VANE DRIVING
3	064-10618	9	VANE - PRE-ROTATION
4	064-10819	9	WASHER, 1 1/4 OD X 25/64 ID X 23/32 TH.
5	064-10818	9	ARM - VANE
6	064-09289	9	WASHER - SPECIAL, 1 1/8 DIA X 3/8 TH.
7	021-11956	9	SCREW - CAP, 12 PT. HD. 3/8-24UNF X 2 1/4 LG.
8	029-07017	9	SCREW - BALL
9	021-11973	AS REQ'D	WASHER, 17/64 ID X 1/2 OD X .016 TH.
10	021-12943	9	NUT, 12-POINT 1/4-28NF

FIG. 9- Cross Section View of Pre-Rotation Device