

ITEM	PART NO.	QUAN.	DESCRIPTION
1	064-14518	1	HOUSING - PRE-ROTATION (T47-T48)
	064-14519		HOUSING - PRE-ROTATION (T53)
	064-14520		HOUSING - PRE-ROTATION (T59)
2	064-09286	1	RING - VANE DRIVING
3	064-09285	9	VANE - PRE-ROTATION
4	064-09290	9	WASHER
5	064-09291	9	ARM - VANE
6	064-09289	9	WASHER - SPECIAL
7	021-11742	9	SCREW - CAP
8	029-07017	9	SCREW - BALL
9	021-11973	AS REQ'D	WASHER
10	021-12943	9	NUT, 12-PT. 1/4-28UNF 3B

FIG. 10 Cross Section View of Pre-Rotation Device

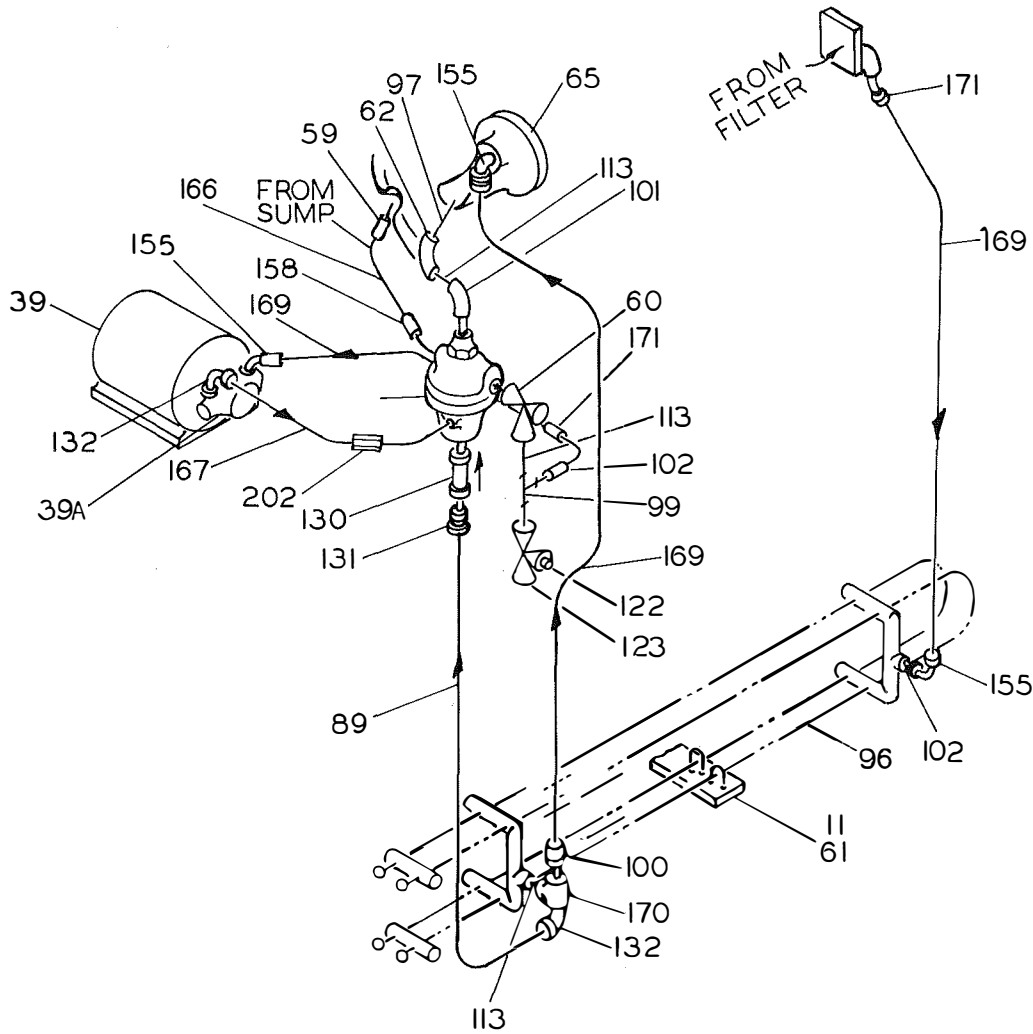

FIG. 11- Oil Piping

Subject to Change Without Notice

Printed in U. S. A.

GP 5M 1168 .20 Code: S(J) & R(J)
Form 160.41-RP1.1

YORK
DIVISION OF BORG-WARNER CORPORATION

