

Dimensions | Flexible Braided Hoses

DIMENSIONS (inches)

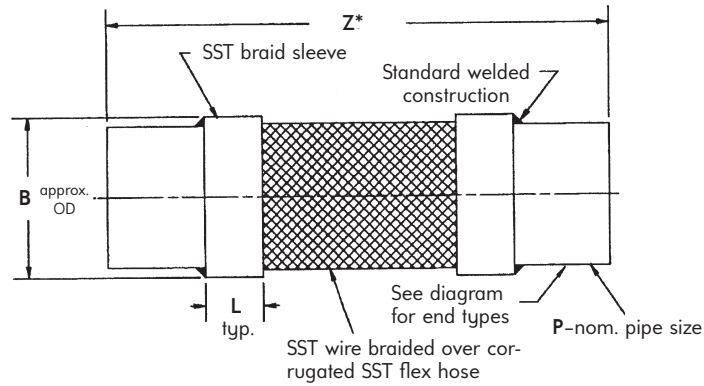

End Types

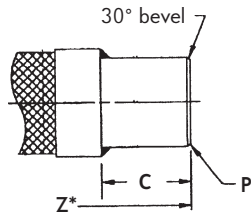
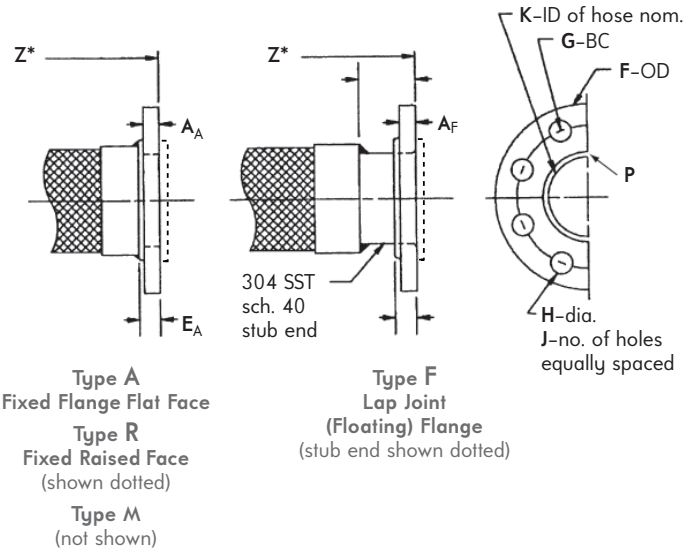

Type W
Butt-weld end

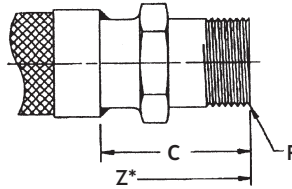

Type T - Threaded end
with hex on 1/2", 3/4", and 1" sizes only

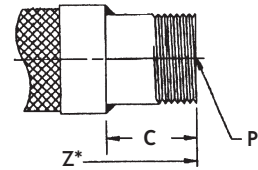

Type T - Threaded end
1 1/4" and larger

Designation	P	NOMINAL REF.			FLANGED END							
		K	B	L	C	A _A	E _A	A _F	F	G	H	J
8773-03	1/4	0.21	0.55	3/4	1 1/8	-	-	-	-	-	-	-
8773-02	3/8	0.35	0.77	3/4	1 3/16	-	-	-	-	-	-	-
8773-01	1/2	0.47	0.94	3/4	1 1/2	3/8	9/16	9/16	3 1/2	2 3/8	5/8	4
8773-0	3/4	0.71	1.23	3/4	1 1/2	7/16	9/16	1/2	3 7/8	2 3/4	5/8	4
8773-1	1	0.96	1.56	3/4	1 3/4	1/2	5/8	9/16	4 1/4	3 1/8	5/8	4
8773-2	1 1/4	1.22	1.91	3/4	2	9/16	3/4	5/8	4 5/8	3 1/2	5/8	4
8773-3	1 1/2	1.45	2.21	3/4	2	5/8	13/16	1 1/16	5	3 7/8	5/8	4
8773-4	2	1.95	2.89	3/4	2 1/2	1 1/16	1 5/16	3/4	6	4 3/4	3/4	4
8773-5	2 1/2	2.44	3.46	1	2 1/4	1 3/16	1 1/16	7/8	7	5 1/2	3/4	4
8773-6	3	2.95	4.09	1	2 3/4	7/8	1 1/8	1 5/16	7 1/2	6	3/4	4
8773-7	4	3.97	5.35	1	2 3/4	7/8	1 1/4	1 5/16	9	7 1/2	3/4	8
8773-8	6	5.82	7.21	1 1/4	3	1 5/16	1 1/2	1	11	9 1/2	7/8	8

See next page for 8" to 12" pipe sizes.

Z* = Minimum recommended over all length (OAL) see Table A on page 4.