

8767E FABRICATED LOW PRESSURE AIR SLIP-ON FLANGES with ANSI 150 TYPE* DRILLING

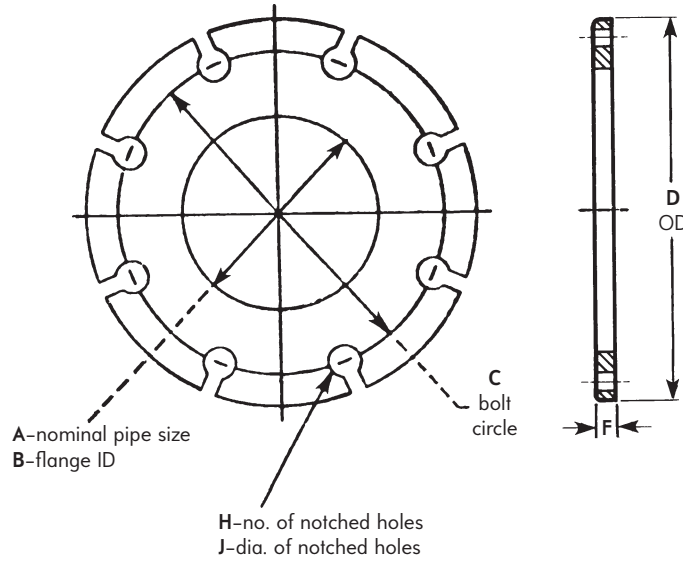

Flange designation	dimensions in inches						
	A	B	C	D	F	H	J
8767E-5	2½	2 ¹⁵ / ₁₆	5½	7	¾	4	¾
8767E-6	3	3 ⁹ / ₁₆	6	7½	¾	4	¾
8767E-7	4	4 ⁹ / ₁₆	7½	9	¾	8	¾
8767E-8	6	6 ¹¹ / ₁₆	9½	11	½	8	7/8
8767E-9	8	8 ¹¹ / ₁₆	11¾	13½	½	8	7/8
8767E-10	10	10 ⁷ / ₈	14¼	16	½	12	1
8767E-12	12	12 ⁷ / ₈	17	19	½	12	1
8767E-14	14	14 ³ / ₁₆	18¾	21	5/8	12	1½
8767E-16	16	16 ³ / ₁₆	21¼	23½	5/8	16	1½
8767E-18	18	18 ³ / ₁₆	22¾	25	5/8	16	1¼
8767E-20	20	20 ³ / ₁₆	25	27½	5/8	20	1¼
8767E-22	22		Unavailable--see 8767D Flange data				
8767E-24	24	24¼	29½	32	¾	20	1¾
8767E-26	26		Unavailable--see 8767D Flange data				
8767E-28	28						
8767E-30	30	30¼	36	38¾	¾	28	1¾

*Non-ANSI rated for low pressure combustion air only.

WARNING: Situations dangerous to personnel and property may exist with the operation and maintenance of any combustion equipment. The presence of fuels, oxidants, hot and cold combustion products, hot surfaces, electrical power in control and ignition circuits, etc., are inherent with any combustion application. Components in combustion systems may exceed 160°F (71°C) surface temperatures and present hot surface contact hazard. Fives North American Combustion, Inc. suggests the use of combustion systems that are in compliance with all Safety Codes, Standards, Regulations and Directives; and care in operation.



CONTACT US:
Fives North American Combustion, Inc.
4455 East 71st Street - Cleveland, OH 44105 - USA
Tel: +1 216 271 6000 - Fax: +1 216 373 4237
Email: fna.sales@fivesgroup.com



www.fivesgroup.com