

North American 8484-3000 Recuperator Radiant Tube Type

Sheet 8484-1

CAPACITIES: 2000 to 4000 scfh air
FLUE GAS TEMPERATURE: 2000 F maximum
TYPE: Single tube - counterflow

DESCRIPTION

The 8484-3000 is a hybrid recuperator with a single radiation tube and a manually adjustable, top mounted, bypass damper that can be used to enhance convection heat transfer.

With the damper open the recuperator functions primarily as a radiation type with some assist by convection transfer to a secondary surface suspended in the flue gas passage.

With the bypass damper closed, flue gas pressure drop and convection heat transfer are at maximum values while radiation transfer is only slightly reduced. Total heat transfer and air preheat temperature are highest in this condition.

While on some applications preheat temperature of more than 1000 F can be realized, it is suggested that temperature be limited to a nominal maximum of 900 F unless testing or observation of radiant tube temperature profile under operating conditions is possible. If the air preheat obtained with the given flue temperature is too high, open the bypass damper to lower preheat air temperature.

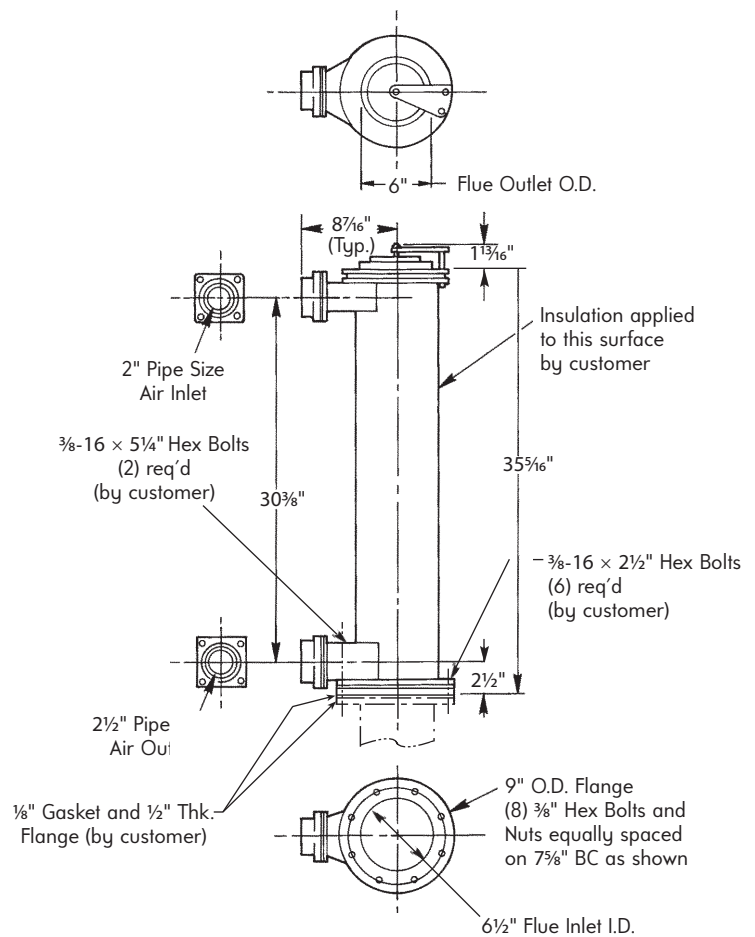

Weight: 70 pounds

8484-3000 OVERALL DIMENSIONS

Metric Conversions

1 scfh = 0.028 26 sm³/h = 0.026 86 nm³/h
 1"wc = 25.40 mm H₂O
 C = 5/9 (F - 32)
 1" = 25.40 mm
 1 lb = 0.4536 kg

DIMENSIONS SHOWN ARE SUBJECT TO CHANGE. PLEASE OBTAIN CERTIFIED PRINTS FROM FIVES NORTH AMERICAN COMBUSTION, INC. IF SPACE LIMITATIONS OR OTHER CONSIDERATIONS MAKE EXACT DIMENSION(S) CRITICAL.

WARNING: Situations dangerous to personnel and property may exist with the operation and maintenance of any combustion equipment. The presence of fuels, oxidants, hot and cold combustion products, hot surfaces, electrical power in control and ignition circuits, etc., is inherent with any combustion application. Parts of this product may exceed 160F in operation and present a contact hazard. Fives North American Combustion, Inc. urges compliance with National Safety Standards and Insurance Underwriters' recommendations, and care in operation.