

For diaphragm replacement kits, order the following:

7052-01: Order **7052-01-RK** consisting of 2-6250-1 air diaphragm and gasket assembly, 2-6249-1 oil diaphragm and gasket assembly, 2-2472-1 a second oil diaphragm.

7052-01-V: Order **7052-01-VRK** consisting of 2-6250-2 Viton air diaphragm and gasket assembly, (2) 2-2472-2 oil diaphragms, 2-5650-2 oil diaphragm gasket.

① Is an oil diaphragm and gasket assembled.

② When ordering a spring cartridge cap, also order an "O" ring.

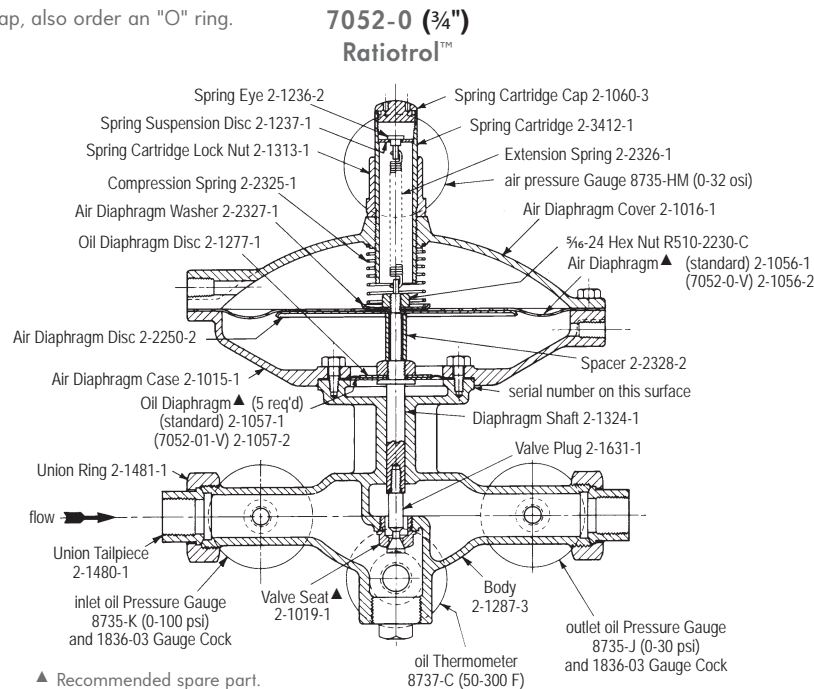

WARNING: Situations dangerous to personnel and property may exist with the operation and maintenance of any combustion equipment. The presence of fuels, oxidants, hot and cold combustion products, hot surfaces, electrical power in control and ignition circuits, etc., are inherent with any combustion application. Components in combustion systems may exceed 160°F (71°C) surface temperatures and present hot surface contact hazard. Fives North American Combustion, Inc. suggests the use of combustion systems that are in compliance with all Safety Codes, Standards, Regulations and Directives; and care in operation.

CONTACT

fna.sales@fivesgroup.com

T +1 800 626 3477 - F +1 216 373 4237

Fives North American Combustion, Inc.
4455 East 71st Street - Cleveland, OH 44105 - USA
www.fivesgroup.com

