

# North American 2408, 12, 16, 20, 24 (D, F) Blowers Part Numbers

Sheet 2400-6DF

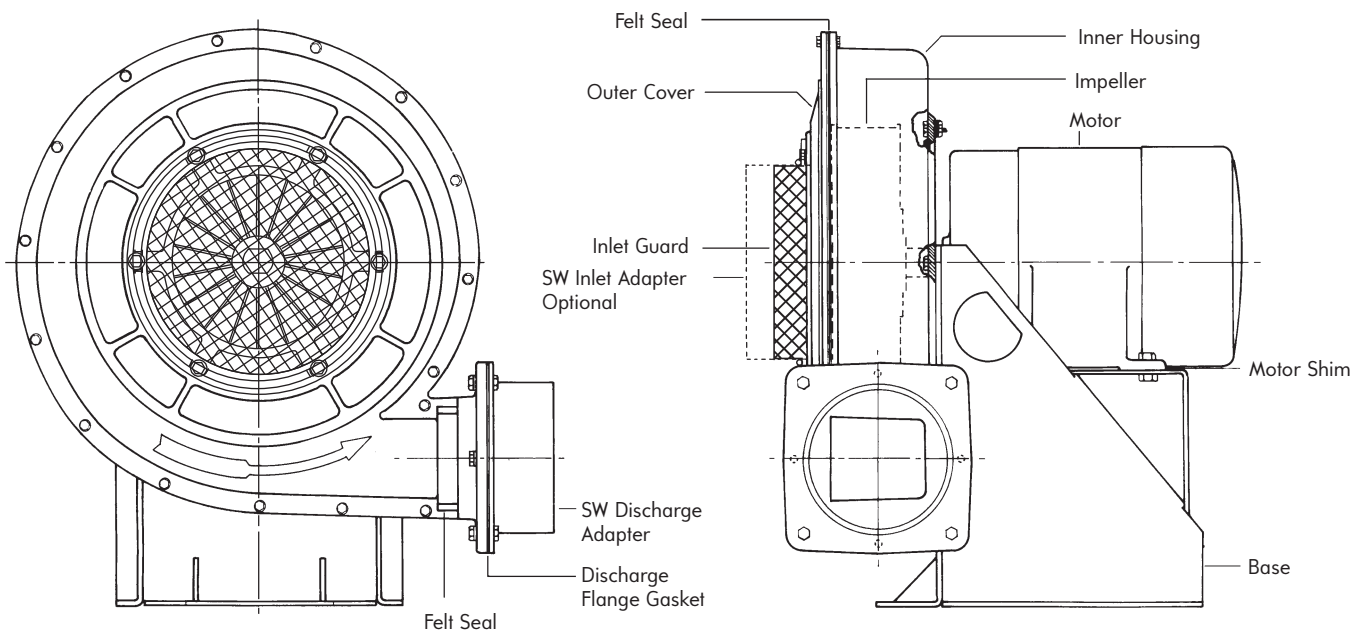

Blower designation	Discharge 1, 2, and 3 base	Discharge 4 base	Inner housing	Outer cover	Impeller	Motor shim	Inlet guard	SW inlet adapter	SW discharge adapter	Discharge flange gasket
2408-D_5	1-2161-2	1-2492-1	1-2170-1	1-2171-1	1-3000-1	1-1662-1	1-3584-5	1-2205-1	1-1678-6	1-2099-2
2408-D_7.5	1-2161-2	1-2492-1	1-2170-1† 1-2170-2‡	1-2171-1	1-3000-3† 1-3000-2‡	1-1662-1† None‡	1-3584-5	1-2205-1	1-1678-6	1-2099-2
2408-F_10	1-2160-2	1-2492-2	1-3944-3	1-2168-1	1-3000-28	1-1662-2	1-3584-4	1-1485-1	1-1680-4	1-0832-3
2408-F_15	1-2160-2	1-2492-2	1-3944-3† 1-3944-2‡	1-2168-1	1-3000-29† 1-3000-30‡	1-1662-2† None‡	1-3584-4	1-1485-1	1-1680-4	1-0832-3
2408-F_20	1-2160-2	1-2492-2	1-3944-2	1-2168-1	1-3000-31	None	1-3584-4	1-1485-1	1-1680-4	1-0832-3
2412-D_7.5	1-2161-2	1-2492-1	1-2170-1† 1-2170-2‡	1-2171-1	1-3000-10† 1-3000-11‡	1-1662-1† None‡	1-3584-5	1-2205-1	1-1678-6	1-2099-2
2412-D_10	1-2161-2	1-2492-1	1-2170-2	1-2171-1	1-3000-12	None	1-3584-5	1-2205-1	1-1678-6	1-2099-2
2412-F_10	1-2160-2	1-2492-2	1-3944-3	1-2168-1	1-3000-40	1-1662-2	1-3584-4	1-1485-1	1-1680-4	1-0832-3
2412-F_15	1-2160-2	1-2492-2	1-3944-3† 1-3944-2‡	1-2168-1	1-3000-41† 1-3000-42‡	1-1662-2† None‡	1-3584-4	1-1485-1	1-1680-4	1-0832-3
2412-F_20	1-2160-2	1-2492-2	1-3944-2	1-2168-1	1-3000-43	None	1-3584-4	1-1485-1	1-1680-4	1-0832-3
2416-D_7.5	1-2161-2	1-2492-1	1-2170-1† 1-2170-2‡	1-2171-1	1-3000-19† 1-3000-20‡	1-1662-1† None‡	1-3584-5	1-2205-1	1-1678-6	1-2099-2
2416-D_10	1-2161-2	1-2492-1	1-2170-2	1-2171-1	1-3000-21	None	1-3584-5	1-2205-1	1-1678-6	1-2099-2