

# North American 6435 Tempest<sup>®</sup> III High Velocity Dual-Fuel Burner

Parts List 6435-5

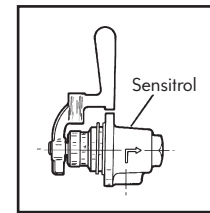
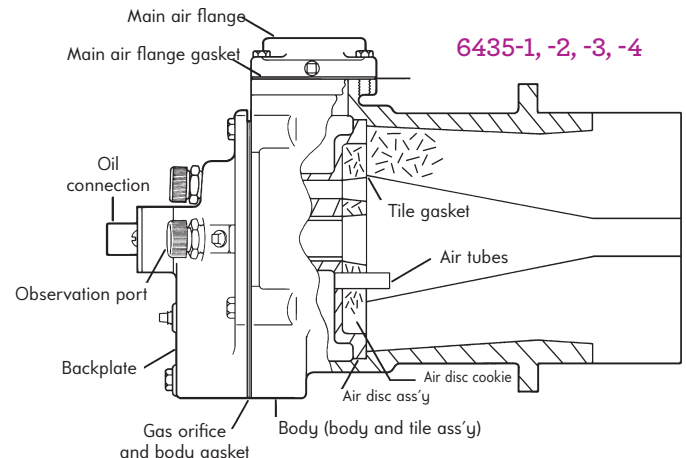
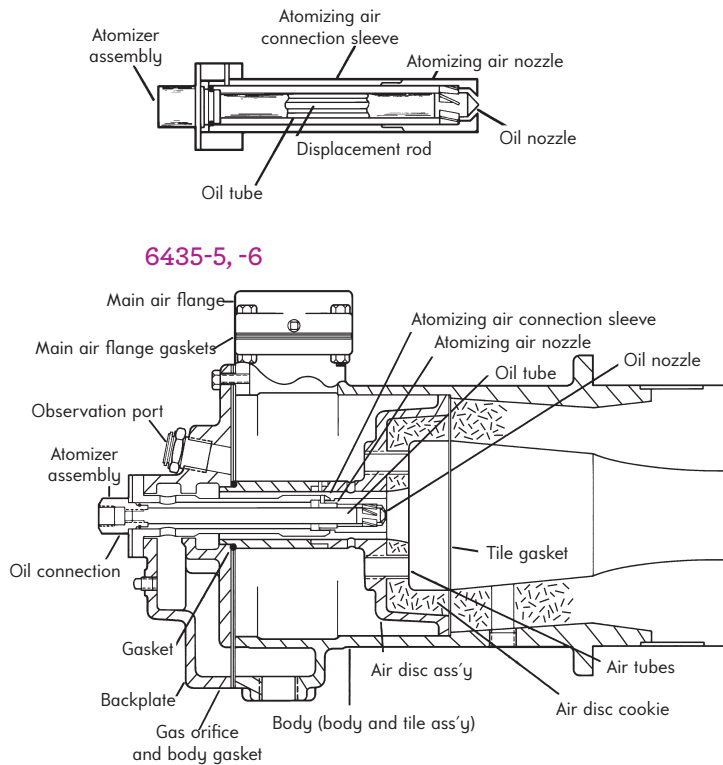

Ordered separately

Part name	Burner designation					
	6435-1	6435-2	6435-3	6435-4	6435-5	6435-6
Air Tubes	3-5925-3 (6)	3-5925-3 (6)	3-5925-4 (6)	3-6004-2 (6)	3-5435-2 (8)	3-5435-3 (8)
Air Disc Assembly (incl. cookie and tubes)	3-6008-1	3-6008-1	3-6008-2	3-6008-3	3-5434-2	3-5434-4
Air Disc Cookie	3-5726-1	3-5726-1	3-5726-1	3-5726-2	3-5411-1	3-5411-1
Atomizer Assembly	3-6007-1	3-6007-1	3-6007-2	3-6007-3	3-6045-1	3-6045-2
Backplate	3-5587-2	3-5587-2	3-5587-4	3-5587-5	3-5448-1	3-5448-1
Body and Tile Assembly	3-5964-1	3-5964-2	3-5964-3	3-5964-4	3-6215-1	3-6044-1
Displacement Rod	3-5725-1	3-5725-1	3-5725-1	—	—	—
Gasket	—	—	—	—	4-3438-2	4-3438-2
Gas Orifice and Body Gasket	3-5028-2	3-5028-1	3-5028-1	3-5001-5	3-5428-1	3-5428-1
Main Air Flange	3-6013-1	3-2544-2	3-2544-1	4-1695-2	4-1695-3	4-1695-9
Main Air Flange Gasket	4-5371-2 (2)	4-5371-2	4-5371-2	4-5371-2	4-5371-2	4-5371-2 (2)
Observation Port	8790-0 (2)	8790-0 (2)	8790-0 (2)	8790-0 (2)	8790-0 (2)	8790-0 (2)
Oil Nozzle	3-5965-1	3-5965-1	3-5965-1	3-5965-1	3-2541-1	3-2541-1
Oirifice Plate	3-5966-1	—	—	—	—	3-6128-1
Sensitrol Oil Valve*	1813-03	1813-03	1813-03	1813-02-A	1813-02-A	1813-02-B
Tile Gasket	3-5718-1 (2)	3-5718-1 (2)	3-5718-1 (2)	3-5718-1 (2)	3-5841-2 (2)	3-5841-2 (2)

\*Not supplied with burner--order separately.