

# North American 4423 and 4424 Gas Burners

Parts List & Instructions 4423/4424

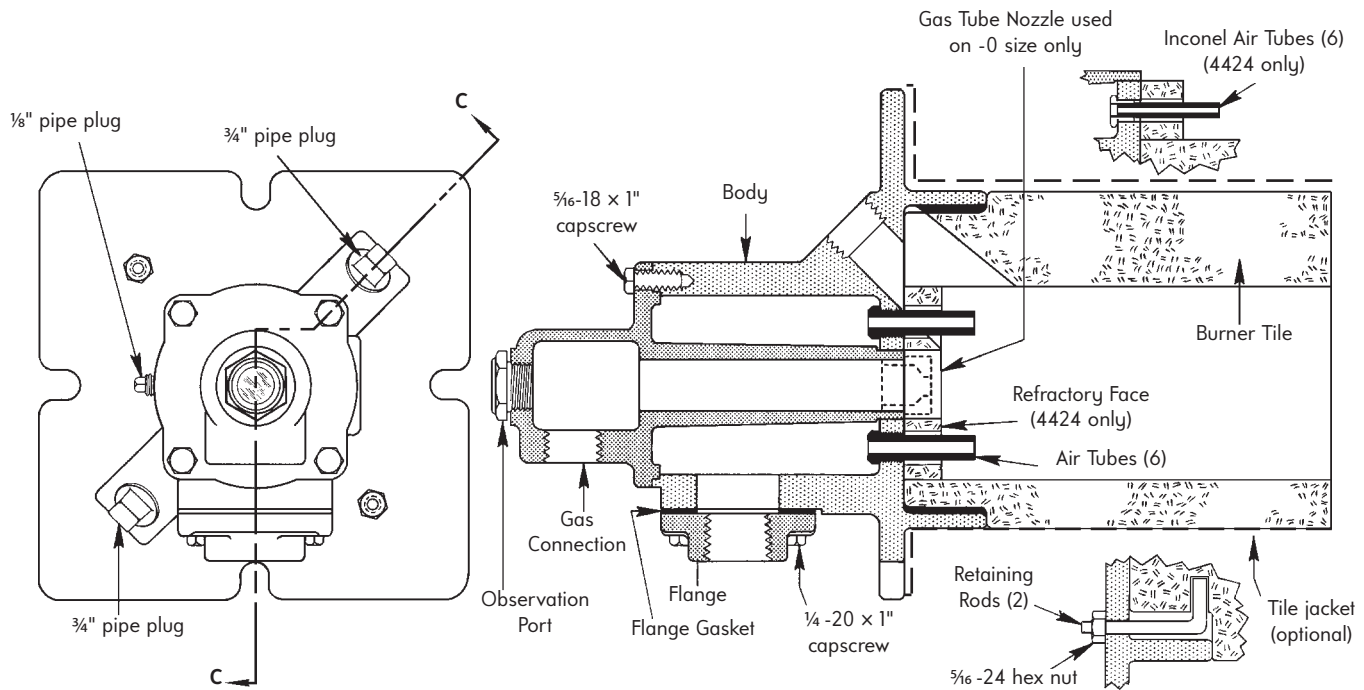

Section C-C

## PARTS for 4423 and 4424 Burners

part name	4423-0	4423-1	4423-2	4423-3-A	4423-3-B
Air Tubes (6)	4-3507-5	4-3507-1	4-3507-2	4-3507-3	4-3507-4
Body	4-3504-2	4-3504-2	4-3504-2	4-3504-2	4-3504-2
Burner Tile	4-2120-2	4-2120-2	4-2120-2	4-2120-2	4-2120-2
Flange	2-4212-1	2-4211-1	2-4170-1	8765-3-B	8765-3-B
Flange Gasket	4-5371-1	4-5371-1	4-5371-1	4-5371-1	4-5371-1
Gas Connection	4-7372-1	4-3503-1	4-3503-2	4-3503-2	4-3503-2
Observation Port	8790-0	8790-0	8790-0	8790-0	8790-0
Retaining Rods (2)	4-2118-2	4-2118-2	4-2118-2	4-2118-2	4-2118-2
Tile Jacket (HRS)*			OB4-0574-1		
Tile Jacket (304 SST)*			OB4-0574-3		
Tile Jacket (309 SST)*			OB4-0574-2		

\* For 4423- -LC, 4424- -L4, and -L9 only.

## ADDITIONAL PARTS for 4424 Burners

part name	4424-0	4424-1	4424-2	4424-3-A	4424-3-B
Inconel Air Tubes (6)	4-5188-1†	4-5189-1†	4-5189-2†	4-5185-4	4-5185-5
Refractory Face	4-5192-2	4-5192-2	4-5192-2	4-5192-2	4-5192-2

†includes 3-3638-1 Adapter