

# Ordering Information & Parts List | Quick Clean Burner

| Fuel Selection                   | 419A - |  | Size Code | Air capacity |                        |
|----------------------------------|--------|--|-----------|--------------|------------------------|
|                                  |        |  |           | Air Inlet    | at 27.7" w.c. (16 osi) |
| 4 for Gas Only                   |        |  | -6-A      | 3"           | 11,000 scfh            |
| 6 for dual Fuel (Gas and #2 Oil) |        |  | -6-B      | 3"           | 16,000 scfh            |
|                                  |        |  | -7-A      | 4"           | 26,300 scfh            |
|                                  |        |  | -7-B      | 4"           | 36,000 scfh            |

Examples: 4419A-6-A Gas Only 11,000 cfh Air at 27.7" w.c. (16 osi)  
6419A-7-A Dual Fuel 27,500 cfh Air at 27.7" w.c. (16 osi)

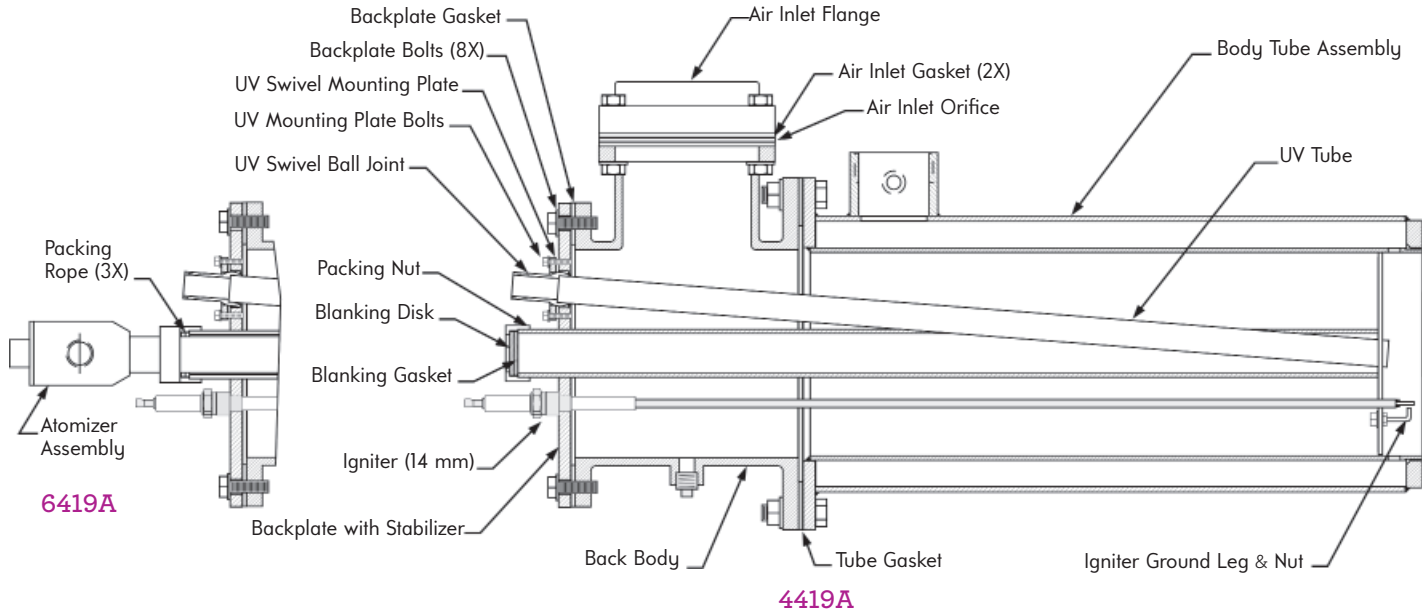

| Part Name                               | 4419A/6419A Series Burner designation |           |           |           |
|---|---------------------------------------|-----------|-----------|-----------|
|   | -6-A                                  | -6-B      | -7-A      | -7-B      |
| Air Inlet Flange                        | 4-1695-4                              | 4-1695-4  | 4-1695-5  | 4-1695-5  |
| Air Inlet Gasket                        | 4-5371-3                              |           |           |           |
| Air Inlet Orifice                       | 4-33089-1                             | 4-33089-2 | 4-33089-3 | 4-33089-4 |
| Back Body (Air Inlet)                   | 4-33088-1                             |           |           |           |
| Backplate with Stabilizer               | 4-57850-1                             | 4-57850-1 | 4-57880-1 | 4-57880-1 |
| Backplate Bolt (8 req'd)                | R069-2500-C                           |           |           |           |
| Backplate Gasket                        | 4-33081-1                             |           |           |           |
| Blanking Disk (4419 only)               | 4-33080-1                             |           |           |           |
| Blanking Disk Gasket (4419 only)        | 4-33079-1                             |           |           |           |
| Body Tube Assembly (Gas Inlet)          | 4-57858-1                             | 4-57858-1 | 4-57878-1 | 4-57878-1 |
| Igniter (14mm Thread)                   | 4-56298-5                             |           |           |           |
| Igniter Ground Leg & Nut                | 4-57868-1                             |           |           |           |
| Observation Port                        | 8790-0                                |           |           |           |
| Oil Atomizer Assembly (6419 only)       | 3-20358-1                             |           |           |           |
| Packing Nut                             | 4-33072-1                             |           |           |           |
| Packing 3 x 3½" (6419 only)             | R540-0120                             |           |           |           |
| Sensitrol™ Oil Valve (6419 only)*       | 1813-02-A                             | 1813-02-B | 1813-02-C | 1813-02-C |
| Tube Gasket                             | OA3-2302-25F4                         |           |           |           |
| UV Swivel Ball Joint                    | 4-32717-1                             |           |           |           |
| UV Swivel Mounting Plate                | 4-57865-1                             |           |           |           |
| UV Swivel Mounting Plate Bolt (2 req'd) | R069-2620-C                           |           |           |           |
| UV Detection Tube                       | 4-33090-1                             | 4-33090-1 | 4-42642-1 | 4-43642-1 |

\* Recommended 1813 Sensitrol Valve is not included as part of burner assembly and must be ordered separately.