

SERIES 3071 INSPIRATORS FOR PRODUCER GAS

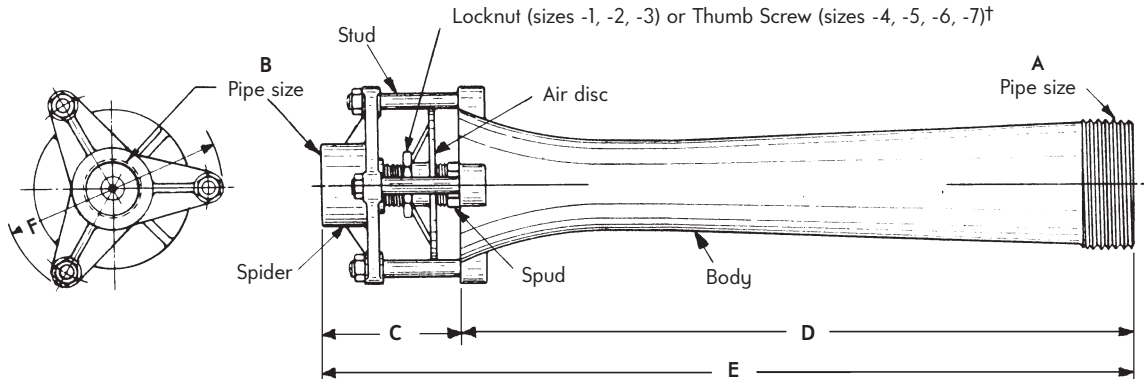

DIMENSIONS SHOWN ARE SUBJECT TO CHANGE. PLEASE OBTAIN CERTIFIED PRINTS FROM FIVES NORTH AMERICAN COMBUSTION, INC. IF SPACE LIMITATIONS OR OTHER CONSIDERATIONS MAKE EXACT DIMENSION(S) CRITICAL.

Inspirator designation	dimensions in inches						wt. in lb	Inspirator designation	Spud drill size	Producer gas capacities in ft ³ /hr			
	A	B	C	D	E	F				8 osi	16 osi	24 osi	32 osi
3071-1-2	1	3/4	2 1/16	7	9 7/16	3 3/16	2 1/4	3071-1-2	No. 2	212	300	370	424
3071-2-S	1 1/4	3/4	2 7/16	8 7/16	10 7/8	3 3/16	3	3071-2-S	S	525	745	910	1 050
3071-3-Y	1 1/2	1	3	10	13	4	5 1/2	3071-3-Y	Y	700	1 000	1 210	1 400
3071-4-35/64	2	1 1/4	3	12	15	4 3/4	8	3071-4-35/64	35/64	1 320	1 870	2 300	2 650
3071-5-23/32	2 1/2	1 1/2	3	14 13/16	17 13/16	5	11	3071-5-23/32	23/32	2 240	3 170	3 880	4 480
3071-6-13/16	3	1 1/2	3 3/16	18 3/4	22 5/16	5 9/16	14 1/2	3071-6-13/16	13/16	2 860	4 040	4 950	5 700
3071-7-1.1875	4	2	3 15/16	21 7/16	25 3/8	6 5/16	25	3071-7-1.1875	13/16	6 100	8 600	10 600	12 200
3071-8-1.875	6	3	6 7/8	30	36 7/8	8 5/8	125	3071-8-1.875	1 7/8	15 300	21 600	26 500	30 600

Capacities of North American Series 3071 Inspirators for Producer Gas of 163 Btu/ft³, 0.86 sp gr, requiring 1 ft³ air/ft³ gas.

Correction Factors for Increased Capacities and Orifice Areas:
90% Primary Air 1.12 80% Primary Air 1.23 70% Primary Air 1.38

Inspirator designation	3071-1-2	3071-2-S	3071-3-Y	3071-4-35/64	3071-5-23/32	3071-6-13/16	3071-7-1.1875	3071-8-1.875
Air Disc	4-2192-1	4-1422-1	4-1419-1	4-1410-1	4-1377-1	4-1417-1	4-1357-1	4-1353-1
Body	4-0276-1	4-0161-1	4-0162-1	4-0160-1	4-1515-1	4-1511-1	4-1518-1	4-1509-2
Locknut	4-0285-1	4-0285-2	4-0285-2	—	—	—	—	—†
Thumb Screw	—	—	—	R777-5210	R777-5210	R777-5210	R777-5210	—†
Spider	4-1425-1	4-1421-1	4-1418-1	4-1409-1	4-1383-1	4-1416-1	4-1355-1	4-1352-1
Spud	4-1427-1	4-1423-1	4-1420-1	4-1411-1	4-1382-1	4-1415-1	4-1356-1	4-1354-1
Stud	4-0287-6	4-0287-6	4-0287-2	4-0287-2	4-0287-2	4-0287-3	4-0287-3	4-0287-4

† 3071-8-1.875 Inspirator has the following additional parts:
Two each: Collar 4-1430-1 Knob 4-1432-1 Screw 4-1431-1
These are in place of Locknut or Thumb Screw. Also 1/2 Flange R590-9542
Gasket R289-1320

A Series 1824K Gas Valve with pipe size matching dimension "B" should be ordered for use with the inspirator.

To order, specify: 3071-(code for pipe size)-(spud drill size) (pipe size) Inspirator.

Example: 3071-8-1.875 6" Inspirator

Or: 1-Gas Pressure and Type 2-Btu/ft³ Content of Gas 3-Specific Gravity
4-Required cfh 5-Percent Air through Inspirator

WARNING: Situations dangerous to personnel and property may exist with the operation and maintenance of any combustion equipment. The presence of fuels, oxidants, hot and cold combustion products, hot surfaces, electrical power in control and ignition circuits, etc., are inherent with any combustion application. Components in combustion systems may exceed 160°F (71°C) surface temperatures and present hot surface contact hazard. Fives North American Combustion, Inc. suggests the use of combustion systems that are in compliance with all Safety Codes, Standards, Regulations and Directives; and care in operation.

CONTACT
fna.sales@fivesgroup.com
T +1 800 626 3477 - F +1 216 373 4237

Fives North American Combustion, Inc.
4455 East 71st Street - Cleveland, OH 44105 - USA
www.fivesgroup.com

fives
 Industry can do it